

Problem 1 – Generating a Voltage Transfer Characteristic

The circuit below features an NMOS transistor that is coupled with a non-linear load device represented by the shaded box. Accompanying the figure is the I-V characteristic for this non-linear load device.

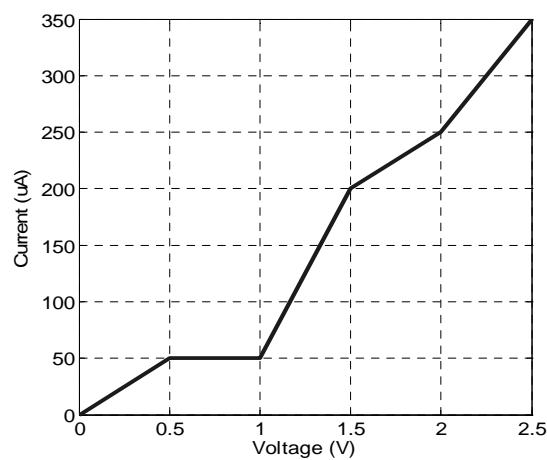
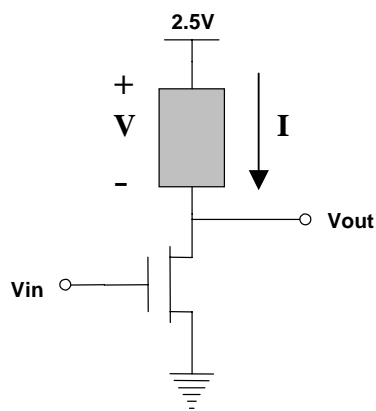

Of course, we also have the family of I-V curves for our NMOS transistor given below (see next page):

- 1A** Draw the VTC for this circuit. Determine (or estimate, if necessary, from your VTC) the following parameters: V_{OH} , V_{OL} , V_M
- 1B** This circuit can be used as an alternative to a traditional CMOS inverter (where the non-linear device is a load to NMOS transistor). From the concepts discussed thus far in lecture and from the results of your VTC, what are the **disadvantages** of this design?

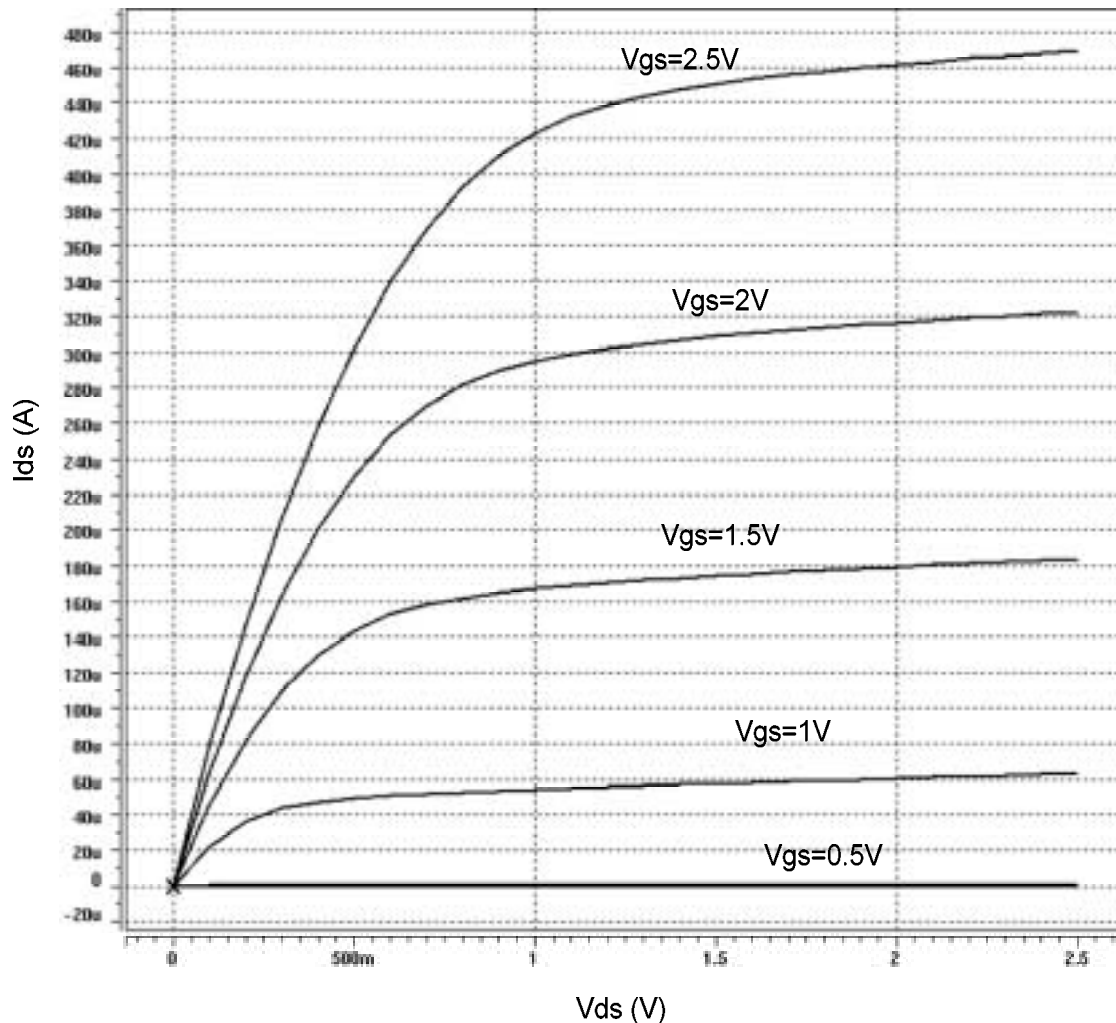

Problem 2 – Analysis Using the Unified Model

Below is another I-V transfer curve for a different NMOS transistor operating under slightly different conditions(see next page):

In this problem, the objective is to use a transfer curve like the one above to obtain the transistor parameters. The transistor has $(W/L)=(20/1)$. You may also assume that velocity saturation does not play a role in this example. Also assume $-2\Phi_F = -0.6V$

2A From the figure on the next page, determine the following parameters: the threshold voltage V_{T0} , body effect parameter γ , channel length modulation parameter λ .

Hint: Depending on your choice of curves, you might get unreasonable values for V_{T0} . Therefore, use the curves with the two lowest V_{gs} values (1V, 1.5V) for the determination of V_{T0} , and explain why using curves with higher V_{gs} doesn't give you sensible answers.

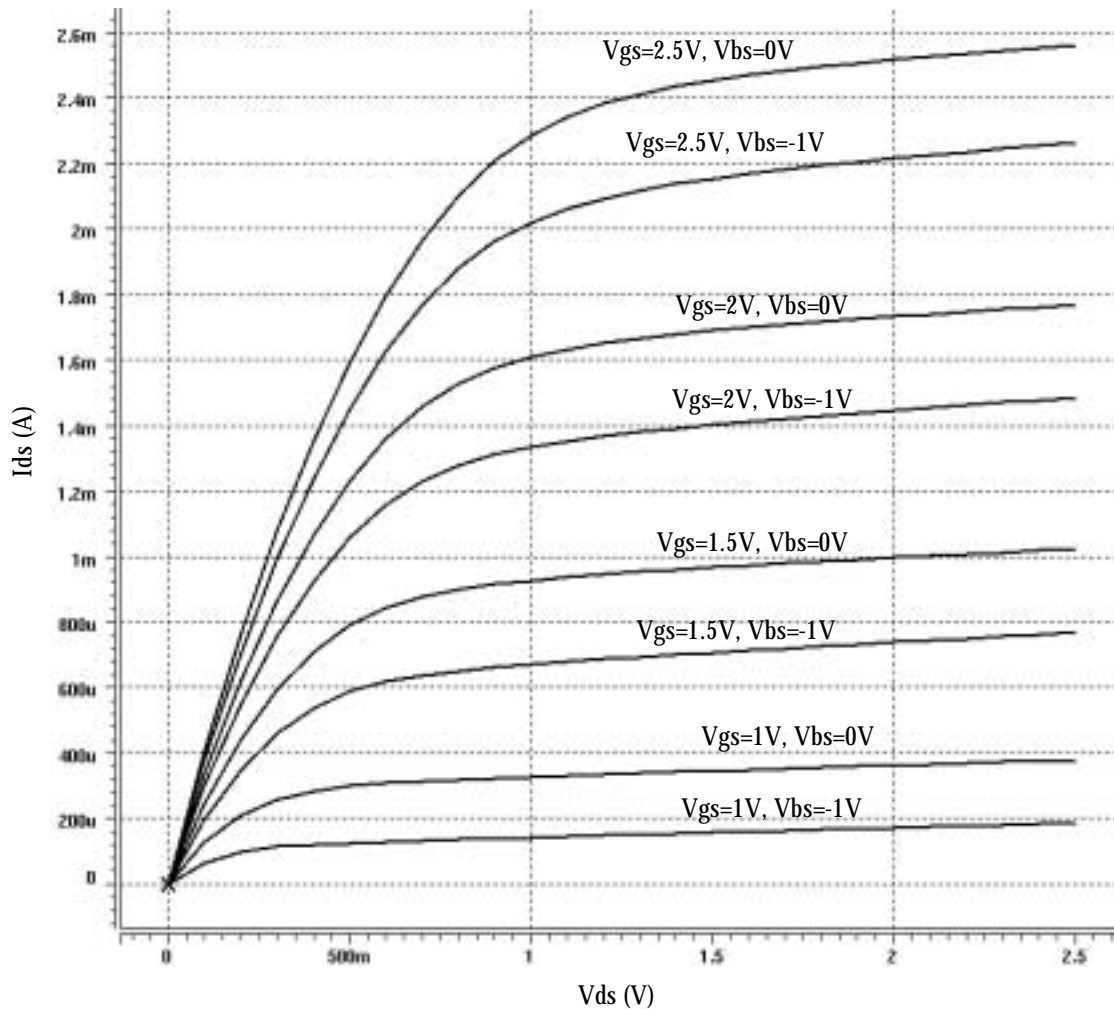

The following part requires you to generate I-V curves for a NMOS transistor. This requires you to have SPICE properly configured on your instructional account.

Make sure you add the following line to your deck:

```
.lib `/home/ff/ee141/MODELS/g25.mod' TT
```

2B Using SPICE, generate the family of curves for a NMOS transistor with the following parameters.

$$W/L = 1.0\mu/0.25\mu$$

Sweep V_{DS} from 0V to 2.5V in 0.1V increments

$V_{GS} = 0V, 0.5V, 1V, 1.5V, 2V, 2.5V$

$V_{BS} = 0V, -0.5V$

Problem 3 – Device Parameters Part 2

Below is a table showing a set of measurements performed on a newly fabricated MOS transistor by an EE143 student. We would like to be able to obtain more information about their parameters without bothering our friends over in the EE143 lab, who already have enough work cut out for them. You are convinced that these measurements are correct and a few assumptions will get you the information that you need.

| Measurement Number | V_{GS} | V_{DS} | V_{SB} | I_D | Operation Region |
|--------------------|----------|----------|----------|-----------|------------------|
| 1 | -2.5V | -2.5V | 0 | -584.29uA | |
| 2 | 1V | -1V | 0 | 0.0 | |
| 3 | -0.7V | -0.8V | 0 | -11.32uA | |
| 4 | -1.9V | -2.5V | 0 | -349.32uA | |
| 5 | -2.5V | -2.5V | -0.8V | -505.69uA | |
| 6 | -2.5V | -1.4V | 0 | -500.10uA | |
| 7 | -2.5V | -0.7V | 0 | -333.19uA | |

You may assume that $V_{DSAT} = -1.0V$ and $-2\Phi_F = 0.6V$.

- 3A** Is the measured transistor a PMOS or an NMOS device? Explain your answer.
- 3B** From measurements above, determine the following parameters: V_{T0} , γ , λ .
- 3C** Complete the missing column in the table above using the values you obtained in 3B. Fill in either “LINEAR”, “CUTOFF”, “SATURATION”, or “VEL. SATURATION.” <You don’t have to recopy the whole table, just the last column is sufficient.>

Problem 4 – RTL Circuit + First Order Delay Analysis

The figure below assembles a RTL circuit where the active device is a PMOS transistor which has a resistive load. Normally in the old days, transistors utilizing RTL design styles employed an NMOS transistor with a resistive load.

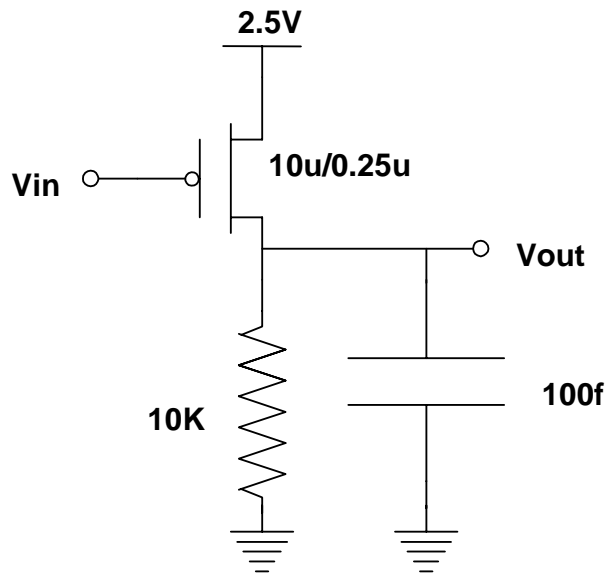

Because we haven't yet covered timing analysis using the full transistor model, you may assume the following information about the problem. Assume the switch model behavior of the PMOS transistor. When $V_{in} > 1.25V$, the resistance of the transistor is infinite. When $V_{in} < 1.25V$, the transistor can be modeled as having a resistance of 10 ohms.

- 4A** Determine the values for V_{OH} and V_{OL} . Explain your answer.
4B Calculate t_{pLH} and t_{pHL} to obtain the average propagation delay, t_p .