

AN INTEGRATED DATA-LINK ENERGY MODEL FOR WIRELESS SENSOR NETWORKS

Lizhi Charlie Zhong¹, Jan M. Rabaey
 Berkeley Wireless Research Center
 University of California, Berkeley

Adam Wolisz
 Telecommunication Networks Group (TKN)
 Technische Universitaet Berlin, Germany

Abstract— In this paper we integrate energy models of all components of the data link layer of a wireless sensor network into a single framework, which interacts with abstracted models of the network layer, the physical layer and the channel. Such a framework enables intra layer and cross layer optimization. By identifying the important design parameters, it provides venues and guidelines for energy reduction and design improvement, as is demonstrated in the paper. The validity of the models is verified using OMNET++ network simulations.

Keywords— sensor networks; power; model; analysis; data-link

I. MOTIVATION

In wireless sensor networks, the power consumption of a node must be kept low. Not only does this greatly reduce the maintenance effort of having to replace the batteries of so many nodes, but also makes the network operation more robust, free from the impact of dead nodes. If the power consumption can be kept sufficiently low ($<100\mu\text{W}$), power obtained through energy scavenging techniques will be enough to keep nodes self-powered. The outcome is very exciting: nodes can be made lighter and smaller; maintenance will be easier and the network operation will be uninterrupted (infinite network life!).

The data link layer (DLL) is part of the protocol stack for wireless sensor networks (Fig. 1). Our DLL [1] has five major components: media access control (MAC), power management (PM), error control (EC), the link layer and power control (PC). They together represent what the DLL does in wireless sensor networks.

Traditionally, people design each layer of the OSI stack independently. While this approach works well in many wired networks, it does not result in good energy efficiency. This is because the design of the DLL is not isolated from that of the network layer or the physical layer (PHY). Besides the interdependencies between the layers, the different components within the DLL interact with one another as well (as shown in Fig. 1). In this paper, we built an integrated framework to address these issues. We model analytically all the components in the DLL as well as the other layers that might impact them. For each component in the DLL, we draw a black box with parameterized inputs and outputs. Our analytical models specify the relationship between the inputs and outputs, for a given design option of this component. Due to the interactions between the components and layers, the output parameters of a component are often related to the input parameters of another component or layer. When we integrate the individual models, we can expose the dependence of the overall power consumption on the design parameters of individual components. This helps us to see what design parameters have the most impact on the overall power consumption. As a result, we can develop new designs that do

well in these key design parameters (at the cost of less important ones).

However, the existence of the closed feedback loops makes the integration much harder. Let us first look at the closed loop between the MAC and link layer, as shown in red thick line in Fig.1. The fixed point theorems can be used to solve this closed loop. As long as both the design of the MAC and link layer are such that the function that maps the inputs to the outputs is continuous and monotonic, we can find the least fixed point using an iterative approach. But there are also other loops in Fig.1. Fortunately these loops are only closed with certain designs. For instance, the loop between the MAC and the PM is closed if and only if the number of active neighbors (N_N) depends on the offered (g). Designs attempting to optimize the PM locally for given N_{NP} and g will produce such dependency. As we have pointed out, designing the PM in an isolated fashion does not result in good overall energy efficiency. As a matter of fact, it turns out that optimizing the PM after the integration achieves lower overall energy consumption. This is due to the fact that the energy can only be lower if we do not put a constraint between N_N and g . If we do optimization after the integration, all loops other than the red thick one will be open, which is what we will assume in the rest of the paper. In summary, we propose in this paper an integrated modeling framework that will help the designers to achieve lower power design than using the traditional approach where each layer or component is designed separately.

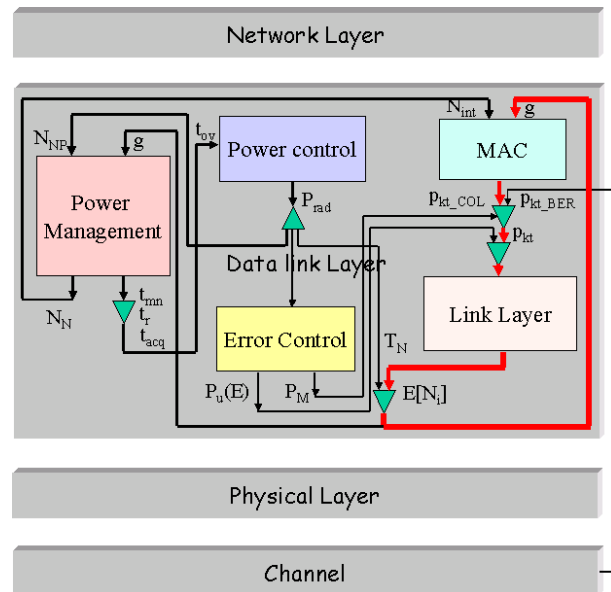

Fig.1 The overall system

¹The author is also affiliated with STMicroelectronics' Berkeley R&D lab. (email: czhong@eecs.berkeley.edu)

II. EXISTING WORK

Below we give a brief survey of the existing literature on low power design as well as the modeling approaches.

Low power MAC design [2]-[9] is one of the most active areas. The main focus is to reduce the collision rate, so the energy in retransmissions can be reduced. Power control is starting to receive more and more attention in sensor networks [10]-[13]. The issue is how to achieve connectivity at the minimum energy cost. The biggest power saving in sensor networks actually comes from the power management. Since a node in a sensor network is inactive most of the time, the energy consumption when it is inactive dominates total energy dissipation. For this reason, many have looked into how to turn off a node when it is not active [2]-[5][14]-[16]. There is also quite a bit of research on the joint design of several DLL components [17][18] [2]-[4] [9].

The modeling approaches used in the above papers and other papers in the literature to evaluate the performance of a design can be categorized into three classes: simulative, experimental and analytical approaches. Their pros and cons are summarized in table 1. Analytical approaches can provide designers much more insight to the design of the DLL within much less time than simulative or experimental ones. They also enable designers to do design optimization. They are the preferred approaches if available. The simulative approaches are used in many of the above papers [2][3][5]-[7][9]-[11][13][14][16]-[18]. Test beds are used in [4][16][19]. [20] [21] give good surveys of many access protocols. But most of these papers focus on the analysis of the throughput and average delay only. [22] has done energy analysis for the simplest access protocols (ALOHA), [15] has performed energy analysis for a two-channel PM and [23] provides analytical bounds on the average number of transmissions for a MAC that uses the receiver to synchronize all the potential transmitters. In addition, [24] has obtained upper bounds on the lifetime of sensor networks. But the work is mainly done for the power control component only.

We have seen from the survey that many designers simply design a component and simulate it. Very often they do not model the other components or layers that have impact on the component they design. Some designers have a channel or network traffic model in their simulations, but the interactions between those and the component they design are never studied. There are some papers on the joint design of several components/layers. These approaches are quite ad-hoc. In other words, these work lack a systematic approach. The analytical models we have seen so far are done for a stand-alone component only. We have not yet seen an integrated framework that can allow designers to bring all the DLL components together with the network layer, the PHY and the channel models.

TABLE 1
COMPARISON OF DIFFERENT MODELING TECHNIQUES

Modeling techniques	Accuracy	Insight	Time to develop	Cost	Controllability
Close form	Low	High	Days	Low	High
Numerical	Medium	Medium	Days	Low	High
Simulation	High	Low	Months	Low	Medium
Test bed	Highest	Low	1+ years	High	Low

The rest of the paper is organized as follows. After a short introduction of the abstracted models for the network traffic, the PHY and the channel, we will provide a black box view of each DLL component, making its interactions with the other components explicit. The closed loop problem is described in section V. We will give the methodology of solving the problem (fixed point) and conditions imposed by the convergence on individual parts. After demonstrating the agreement of our analysis with simulations, we present numerical results that identify the areas of opportunities for power optimization.

III. ABSTRACTED MODELS

The overall system is shown in Fig.1. In this section, we will present the abstracted models for the layers outside the DLL.

A. Network Traffic Model

The network traffic is defined as the packets sent from the network layer to the DLL. A network traffic model not only specifies the traffic rate, but also the traffic pattern.

B. PHY Model

The physical layer is responsible for sending and receiving a bit stream over a wireless channel. An abstracted PHY model gives the power profile, defined as the power consumption in each operating mode of the PHY. The input to the PHY model is the radiated power level set by the PC.

C. Channel Model

The channel attenuates the strength of a signal and adds interference and noise to it. A channel model will provide the average packet error rate from the channel impairment p_{kt_BER} .

IV. DLL MODELS

For the DLL components, we try not restrict ourselves to particular designs. Below we present a black box view of every component. It must be noted that the relationship between the inputs and the outputs does differ from design to design. We have developed one or more designs for each DLL component, and have modeled each of them. Table 2 summarizes the design options for which we have built the models. The description of these designs and their models can be found in [25].

A. MAC Models

The MAC is responsible for managing the usage of channels such that collisions can be controlled. The block diagram for the MAC is shown in Fig. 2. From this diagram, we can clearly see the interactions between the MAC and the other components in the system. Here the radio data rate and the number of channels available are given by the PHY. The offered load g is influenced by traffic from the higher layers, the

TABLE 2
DESIGN EXAMPLES MODELED

DLL	Design Examples
MAC	ALOHA, CSMA with hidden terminals, Multi-channel MAC
EC	CRC
Link	Positive Acknowledgements, Extended ACK and NACK
PM	The full duty cycle receiver, the cycled receiver, the preamble sampling, the wakeup radio, Multi-channel PM
PC	The optimal power level

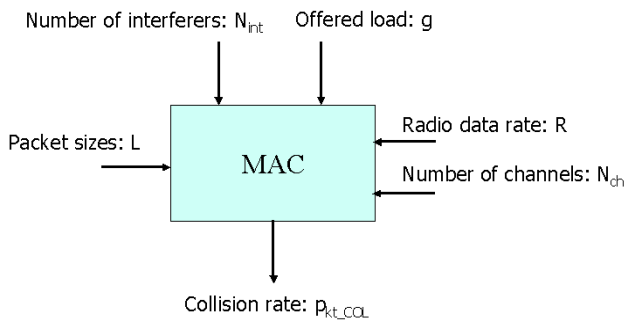

Fig.2 MAC model

hop distance set by the PC, as well as the retransmissions in the link layer. The number of interferers N_{int} depends on the network density and is also closely related to the PC and PM components. The packet sizes are the sizes of the packets from the network layer and the components inside the DLL, for example the link layer and PC. The collision rate has impact on the number of retransmissions seen in the link layer and quality of service (QoS) of a link.

B. Error Control Model

The error control (EC) component detects and/or corrects errors in packets. Fig. 3 is its block diagram. The packet size is the size of every packet excluding the PHY overhead and the redundant bits added by the EC. The packet sizes are determined by the components generating them. The received power and the average BER before coding are related to the channel as well as the radiated power level set by the PC. The probability for an undetected error in every packet changes the number of retransmissions needed in the link layer. The EC influences the other components as well. It changes the total size (L) of a packet through encoding. The complexity of its decoding circuitry impacts the power of PHY in the receive modes (P_{R_BB}). When forward error correction (FEC) is performed, the EC further influences the number of retransmissions in the link layer since the corrected packet needs not be retransmitted. In other words, the probability of a codeword error P_M for a given received power level will change the probability that a packet fails.

C. Link Layer Models

The link layer specifies the handshakes and handles retransmissions. Its interactions with other components are as follows: the MAC and the channel (and the EC if FEC is used) jointly determine the probability of failure for each packet. The

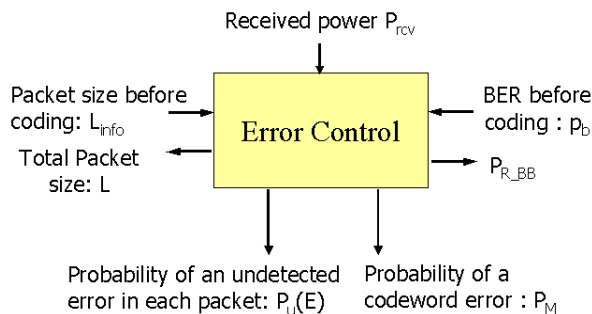

Fig.3 Error control model

EC specifies what fraction of the erroneous packets will be detected. On the other hand, the average number of transmissions for each packet changes the offered load in the MAC and PM components. Fig. 4 is the black box view of any link layer.

D. Power Management Model

The function of the power management component is to turn off a node as much as possible. But the synchronization between the sender and the receiver also needs to be done. The component view of the PM is shown in Fig. 5. The PM is interacting with many components, especially the PC and the PHY. The PC determines the number of physical neighbors and the offered load. The link layer impacts the offered load too through the average number of transmissions. The handshakes in the link layer can also be used to reduce the overhearing. The PHY specifies the radio data rate, the carrier sense time, the power needed for the wakeup radio and the size of the PHY header in every packet. The higher layers set the access window size. The sizes of the packets are determined by the components generating them. In return, the PM specifies the average percentage of time a node spends in each mode, which not only helps us to compute the average power consumption, but also strongly influences the power level used in the PC. The PM also changes the number of interferers, which is very important to the MAC.

E. Power Control Model

The power control component sets the radiated power level P_{rad} or equivalently the hop distance d_H . The power control is usually done for one or all of the following reasons: to maintain the connectivity, to reduce the power consumption or to reduce the interference. Its block diagram is shown in Fig. 6. The higher layers give the density of the network. G is related to the antenna gain, power efficiency of the power amplifier and the receiver sensitivity. The channel determines the path loss exponent n. The power in receive modes is given by the PHY. The time a node spends in receiving and overhearing for each network packet is determined by the PM. The radiated power level decides the power in the transmit mode of the PHY. In addition, it also determines the number of the physical neighbors and impacts the network traffic density (and eventually the offered load seen by the MAC and PM components). The number of the physical neighbors N_{NP} is:

$$N_{NP} = \pi \cdot D \cdot d_H^2 \tag{1}$$

If we define APDR to be the application data rate, or the number of application events per second per node, and d to be the distance between a source and a destination, the average

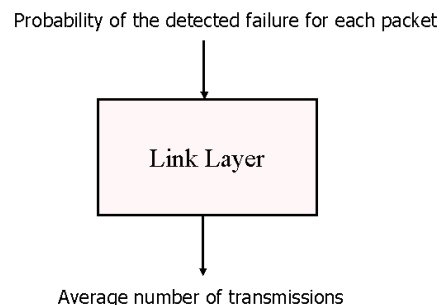

Fig.4 The link layer model

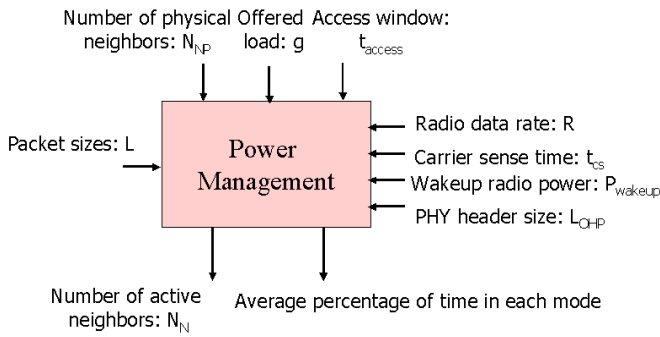

Fig.5 Power management model

number of network events per second per node or the network traffic density is:

$$T_N = E[APDR] \cdot \frac{\bar{d}}{d_H} \quad (2)$$

The offered load for packet i is the product of T_N and the number of transmissions of the packet:

$$g_i = T_N \cdot E[N_i] \quad (3)$$

V. THE FIXED POINT THEOREMS

In this section, we address the closed loop problem shown in Fig.1 using the fixed point theorems.

Definition 1: (partially ordered set) A partially ordered set (poset), is a set S with the following order properties: 1) $a \leq a$ $\forall a \in S$; 2) $a \leq b$ and $b \leq c \Rightarrow a \leq c$; 3) $a \leq b$ and $b \leq a \Rightarrow a = b$.

A set with a bottom is a poset.

Definition 2: (chain) A chain is a fully ordered subset of a partially ordered set.

Definition 3: (CPO) A set is a complete partially ordered (CPO) set if every chain Y in the set has a lowest upper bound, denoted by $V(Y)$, and $V(Y)$ is inside the set.

Definition 4: A function f is monotonic if $f(x_1) \leq f(x_2)$ for any $x_1 \leq x_2$.

Definition 5: A function f is F-continuous if for every chain Y in a CPO, $V(f(Y)) = f(V(Y))$.

Theorem 1: The set where the vector of the packet error rates for all packets belongs to is a CPO.

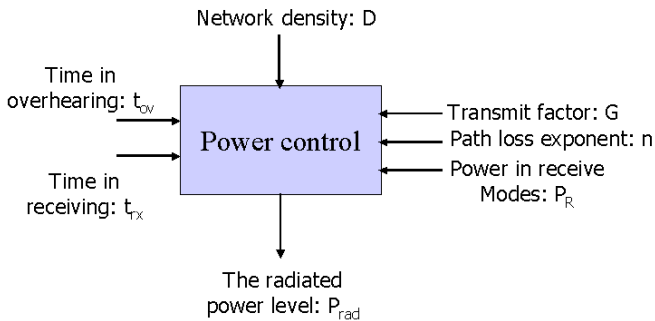

Fig.6 Power control model

Proof: Since the packet error rate of a packet is a probability, the vector of the packet error rates for all packets belongs to the set $[0,1]^{N_{msg}}$, where N_{msg} is the number of packet types. This set is real valued, closed, and partially ordered with the all 0 vector as the bottom and the all 1 vector as the top. Every chain $\{\vec{x}_n\}$ in $[0,1]^{N_{msg}}$ is a non-decreasing sequence. A non-decreasing sequence bounded by the all 1 vector has a limit, which is also the lowest upper bound of the sequence. Because $[0,1]^{N_{msg}}$ is a closed set, the limit is in the set. Since every chain in $[0,1]^{N_{msg}}$ has a lowest upper bound and the lowest upper bound is inside the set, $[0,1]^{N_{msg}}$ is a CPO. ■

Theorem 2: The function f is also F-continuous if it is monotonic and continuous.

Proof: Given a chain $\{\vec{x}_n\}$ in $[0,1]^{N_{msg}}$, $f(\vec{x}_n)$ is also a non-decreasing sequence in $[0,1]^{N_{msg}}$ since f is monotonic. From the proof of Theorem 1, we know that a non-decreasing sequence in $[0,1]^{N_{msg}}$ has a limit and the limit is its upper bound. Therefore, $\lim_{n \rightarrow \infty} f(x_n) = V(f(x_n))$ and $\lim_{n \rightarrow \infty} x_n = V(x_n)$. f being a continuous function implies $\lim_{n \rightarrow \infty} f(\vec{x}_n) = f(\lim_{n \rightarrow \infty} \vec{x}_n)$. It follows that $V(f(x_n)) = \lim_{n \rightarrow \infty} f(x_n) = f(\lim_{n \rightarrow \infty} x_n) = f(V(x_n))$. By Definition 5, f is a F-continuous function. ■

Theorem 3: (Brouwer's theorem) Every continuous mapping f of a closed n -ball to itself has a fixed point.

Theorem 4: (Banach's fixed point theorem) If X is a CPO with bottom \perp , and $f: X \rightarrow X$ is F-continuous, then f has a least fixed point x and we can find x constructively by obtaining the lowest upper bound of the following chain: $\{\perp, f(\perp), f(f(\perp)), \dots\}$.

In our case, f is continuous. By Brouwer's theorem, at least one fixed point exists. In addition, f is monotonic for most cases. This can be seen without writing down the formulas. When the packet error rates for all packets \vec{X} increase, generally the numbers of transmissions for all packets go up. As a result, the channel gets more crowded and the packet error rates for all packets $f(\vec{X})$ will be higher. It follows from Theorem 2 that f is F-continuous. By Theorem 4 we can always find the least fixed point of the packet error rate vector by starting at the all zero vector and keeping applying function f to it. This can be easily done using MATLAB. In summary, to solve the closed loop problem, we only require that the MAC function and the link layer function are monotonic and continuous. Exactly what designs are used for them does not matter.

VI. VERIFICATION OF OUR MODELS

In our models, we have made a number of assumptions, some of which might be simplifications. Examples of such are:

- Retransmissions are Poisson distributed
- Channel is independent between packets
- Collisions are independent from channel errors
- Receiver is always ready

We use OMNET++ network simulation to verify our analysis. In our simulation, we make none of the above assumptions. The network traffic model is Poisson and the channel model is the simplified Gilbert Elliott model, same as those used in our analysis. For both approaches, we use the same PHY and the same DLL. The DLL uses a two-channel carrier sense multiple access (CSMA) as the MAC, extended ACK and NACK as the link layer, the cyclic redundancy check as the EC, the wakeup radio as the PM and the PC uses the optimal power level. We simulate a network of 24 nodes for an hour. Fig. 7 shows the topology of the network in OMNET++. The two icons with red bar are the two channels used in our MAC.

Fig. 8 shows the energy per useful bit obtained from both approaches. We can see that even though these two represent different modeling approaches, their results match each other quite well.

VII. NUMERICAL RESULTS

All models used in this section can be found in [25]. Here we briefly describe the three PM designs used below. The full duty cycle receiver does not turn off a node when it is idle. In contrast, the cycled receiver lets a node to sleep most of the time. A node is powered on only for a short amount of time for every cycle. A potential sender needs to wait until the first candidate is powered on. The wakeup radio uses an extra radio to wake up the receiving node so the above waiting time can be reduced.

A. Impact of the radio data rate

One application of our modeling framework is to enable a system architect to understand the impact of key design parameters. He can then go one step further to make the right design tradeoff. We use the radio data rate as an example. The

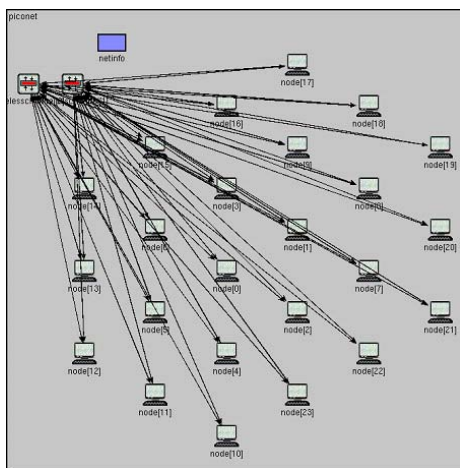

Fig. 7 Simulation in OMNET++

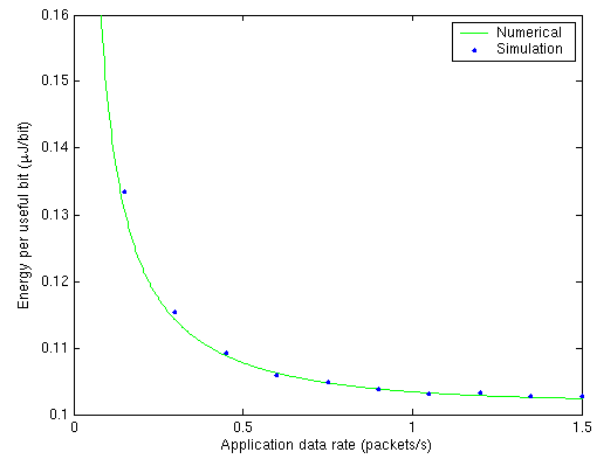

Fig. 8 Comparison of the numerical result to the simulation result

choice of the radio data rate has impact on many parts of a system, including the PHY, the PM and the MAC. We can use our integrated modeling framework to demonstrate the overall effect of the radio data rate on the average power consumption. The results are shown in Fig. 9.

A special PHY design is used in this analysis [25]. An A/D is not used in this PHY to achieve ultra low power consumption. Given that, the power consumption of the RF front end in the receive chain is relatively insensitive to the data rate. The same is true for the power consumption of the oscillator. The power consumption of the digital base band (DBB) in the receive chain increases linearly with the data rate for all three modes. Lastly the power consumption of the power amplifier (PA) increases only sub-linearly with the data rate because an envelope detector is used in this PHY. More accurately, when the radio data rate is increased by k times, P_{rad} only has to be increased by \sqrt{k} times to keep the received energy per bit the same.

The effect of the data rate on the PM is as follows: when the radio data rate is increased, a node will spend less time in transmitting and receiving. When proper power management is used, the time in the monitor mode will be reduced as well. The data rate influences the MAC too: the higher the data rate is, the less time it takes for a packet to use the channel, and the less the number of collisions is. In summary, when the data rate increases, on one hand the power consumption in each mode increases; on the other hand, the time that a node stays on will be reduced and less energy will be spent on retransmissions. One cannot see the overall effect without using an integrated modeling framework like ours.

Fig. 9 shows that for the cycled receiver the overall effect is that the average power goes down when the data rate increases. But the opposite is true for the full duty cycle receiver (FDCR). This is because the time in the monitor mode dominates in FDCR and does not decrease with the data rate. Consequently, the average power consumption goes up instead. So we can conclude that with proper power management, using the highest radio rate possible is always a good thing. But it should be noted that we couldn't increase the radio data rate infinitely. The envelope detector used in this PHY suffers from the inter-

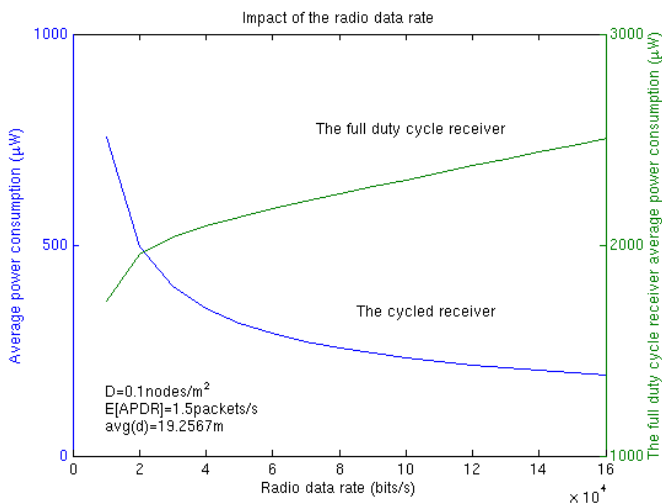

Fig.9 Impact of the radio data rate

symbol interference at higher data rate. The highest data rate it can be used at is about 160 kbps.

B. Comparison of the wakeup radio to the cycled receiver

The cycled receiver and the wakeup radio are the two possible design alternatives for the PM. Here we use the comparison of the two as an example. Fig. 10 shows under what conditions the cycled receiver is better than the wakeup radio. For example, when the network density is 1 node/m² and the average application data rate is 1.5 packets/s, the cycled receiver is better than the wakeup radio if the extra radio used to do wakeup consumes more than 80uW. This threshold changes with the average application data rate and the network density. When the application data rate is lower, it would be easier for the cycled receiver to beat the wakeup radio. The cycled receiver can also take advantage of the increased network density. This is due to the fact that the duty cycle of every node can be reduced more when a network is denser.

C. The joint design of the power control and the power management

We use this example to show that our modeling framework

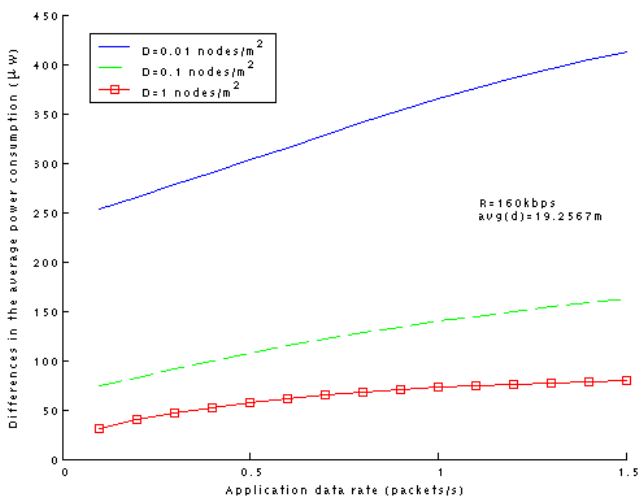

Fig.10 Comparison between the wakeup radio and the cycled receiver

can help designers to invent new algorithms. The PC sets the hop distance d_H . Among the ones that ensure a connected network, the optimal hop distance d_{Hopt} is the one that results in the lowest overall power consumption. Fig.11 shows the influence of the network density on d_{Hopt} . The cycled receiver with the optimal duty cycle is used as the PM. We can see from Fig.11 that there exist three areas: high slope linear, small slope and almost flat.

A network is sparse in the first area, where connectivity requirement dominates. Our framework shows $d_{Hopt} = d_{min}$, the minimum hop distance needed for connectivity. This explains why d_{Hopt} changes linearly with the network density in this area. Consequently, accurate power control is needed in this region.

The curve stabilizes in the third area where a network is very dense, because the increasing density leads to smaller headroom for us to increase d_H while still reducing the overall power consumption. The PC in this case will set a fixed power level for every node. This power level corresponds to d_{Hopt_inf} , the optimal hop distance when the network is infinitely dense. The duty cycle of the cycled receiver will be set based on this power level. It will be very low since a node has many neighbors and can afford to allow each of them to sleep longer. In fact, it has to be low enough to ensure N_m is not too high.

The most interesting networks are the ones with densities in between. Fig.11 shows d_{Hopt} for these networks are higher than d_{Hopt_inf} and the amount of increase reduces as a network becomes more and more dense. This is because when d_H is slightly increased from d_{Hopt_inf} , more candidates will be available in the neighborhood, enabling us to reduce the duty cycle of each candidate further. As a result, the power in the monitor mode will be reduced, contributing to the reduction in the overall power consumption. But as density increases, the power in the monitor mode for each candidate is already very low at d_{Hopt_inf} , leading to smaller headroom for us to

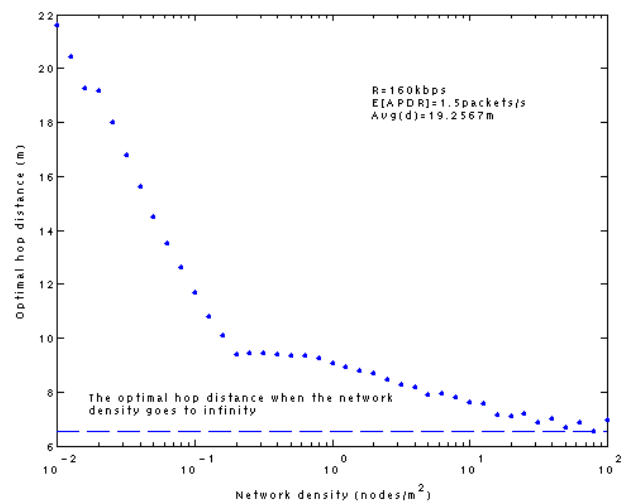

Fig.11 Optimal hop distance as a function of the network density

Increase d_H while still reducing the overall power consumption. It is obvious by now we cannot simply set d_H to d_{Hopt_inf} as in very dense networks, instead we need to set d_H together with the duty cycle, which results in a d_{Hopt} higher than d_{Hopt_inf} .

In conclusion, our modeling framework tells us a design must be different for different network density. Table 3 summarizes the designs for these three zones. We can see from Fig.11 that the intermediate zone includes networks whose densities are between 0.1 nodes/m² and 10 nodes/m². Most of sensor networks fall into this zone where the co-design of the power control and power management can achieve lower energy consumption.

TABLE 3
Three design zones based on network density

Zones	Characteristics	Design
Sparse	$d_{Hopt} = d_{min}$	Accurate power control
Intermediate	Between the other two	The power level needs to be set together with the duty cycle
Very dense	d_{Hopt} is within 10% of d_{Hopt_inf}	The power level is set in disregard to the duty cycle. PM is used to reduce N_N afterwards

VIII. CONCLUSION

An integrated modeling framework is presented for the first time in this paper. Due to space constraints, we can only give a few examples to demonstrate its usefulness. In reality, a rich amount of information can be obtained from this framework, which can help system architects to identify the critical regions for energy savings and enable designers to achieve lower power designs than using traditional approaches. In fact, the guidelines resulting from this analysis have already had a real impact on the design of an actual sensor network.

ACKNOWLEDGMENT

This work is funded by DARPA under the PAC/C program. We would like to thank Bhusan Gupta of STMicroelectronics for his support. Part of this research (e.g. OMNET++ simulations) was done in STMicroelectronics' Berkeley R&D lab. Prof. Edward A. Lee in the Department of EECS at UC Berkeley has helped us in solving the closed loop problem using the fixed point theorems. We further thank Martin Kubisch and Andreas Willig of the Technical University of Berlin for sharing their knowledge on the OMNET++ simulator as well as the Gilbert-Elliott channel model. Lastly, but not the least, the support of Adam Wolisz's research by the Volkswagenstiftung, European Commission and German Ministry of Research (BMBF) is highly acknowledged.

REFERENCES

[1] L. C. Zhong, J. M. Rabaey, C. Guo and R. Shah, "Data link layer design for wireless sensor networks", *Proc. MILCOM 2001*, vol.1, p.352-6, October 2001.

[2] K. M. Sivalingam, M. B. Srivastava, P. Agrawal and J. Chen, "Low power access protocols based on scheduling for wireless and mobile ATM networks", *1997 IEEE 6th International Conference on Universal*

Person Communications Record, San Diego, CA, USA, 12-16 Oct. 1997.

[3] K. Sohrabi and G. Pottie, "Performance of a novel self-organization protocol for wireless ad-hoc sensor networks", *50th IEEE Vehicle Technology Conference*, The Netherlands, September 1999.

[4] W. Ye, J. Heidemann and D. Estrin, "An energy efficient MAC protocol for wireless sensor networks", *IEEE Infocom 02*, June 2002.

[5] L. C. Zhong, R. Shah, C. Guo and J. M. Rabaey, "An ultra-low power and distributed access protocol for broadband wireless sensor networks", *Network+Interop: IEEE broadband wireless summit*, Las Vegas, May 2001.

[6] S. Lee and D. Cho, "Distributed reservation CDMA for wireless LAN", *IEEE GLOBECOM '95*, Singapore, 13-17 Nov. 1995.

[7] D. Lopez-Rodriguez and R. Perez-Jimenez, "Distributed method for channel assignment in CDMA based ad hoc wireless local area networks", *1999 IEEE MTT-S International Topical Symposium on Technologies for Wireless Applications*, Vancouver, BC, Canada, 21-24 Feb. 1999.

[8] M. Joa-Ng and I. Lu, "Spread spectrum medium access protocol with collision avoidance in mobile ad-hoc wireless network", *IEEE INFOCOMM 1999*, New York, NY, USA, 21-25 March 1999.

[9] C. Guo, L.C. Zhong and J.M. Rabaey, "Low power distributed MAC for ad hoc sensor radio networks", *IEEE Globecom 01*, November 2001.

[10] V. Rodoplu and T. Meng, "Minimum energy mobile wireless networks", *IEEE J. Selected Areas in Communications*, vol.17,no.8, pp.1333-1344, August 1999.

[11] R. Wattenhofer, L. Li, P. Bahl and Y.Wang, "Distributed topology control for power efficient operation in multihop wireless ad hoc networks", *Proc. INFOCOM 2001*, April 22-26 2001.

[12] S. Borbash and E. Jennings, "Distributed topology control algorithm for multihop wireless networks", *Proc. IJCNN 02*, vol.1, pp. 355-360, May 2002.

[13] M. Kubisch, H.Karl, A.Wolisz, L.C. Zhong and J.M.Rabaey, "Distributed algorithms for transmission power control in wireless sensor networks", *WCNC 03*, March 2003.

[14] G. Pei and C. Chien, "Low power TDMA in large wireless sensor network", *Proc. MILCOM 2001*, vol.1, pp.347-51, October 2001.

[15] C. Schurgers, V. Tsiftis, S. Ganeriwal and M. Srivastava, "Optimizing sensor networks in the energy-latency-density design space", *IEEE Trans. Mob. Comp.*, vol.1, pp.70-80, January-March 2002.

[16] Y.Xu, S.Bien, Y.Mori, J.Heidemann and D.Estrin, "Topology control protocols to conserve energy in wireless ad hoc networks" submitted to *IEEE Trans. Mob. Comp.*, January 2003.

[17] J. P. Ebert and A.Wolisz, "Combined tuning of RF power and medium access control for WLANs", *Proc. IEEE Intl. Workshop on Mobile Multimedia Communications*, pp. 74-82, San Diego, November 1999.

[18] C. Guo, Ph.D. dissertation, UC Berkeley, 2003.

[19] R. Stutz, "Performance analysis and optimization of 2.4GHz multi-hop, wireless self-configurable network", M.S. report, UC Berkeley, 2003.

[20] R. Rom and M. Sidi, *Multiple access protocols-performance and analysis*, Springer-Verlag, 1990.

[21] N. Abramson, *Multiple access communications*, IEEE Press, New York.

[22] A. El-Hoiydi, "Aloha with preamble sampling for sporadic traffic in ad hoc wireless sensor networks", *IEEE ICC 2002 Computer Society Workshop on VLSI*, New York, NY, USA, 28 April -2 May 2002.

[23] S. Khanna, S. Sarkar and I. Shin, "An energy measurement based collision resolution protocol", *International Teletraffic Congress (ITC18)*, Berlin, Germany, September 2003.

[24] M. Bhardwaj and A.P. Chandrakasan, "Bounding the life time of sensor networks via optimal role assignments", *Proc. INFOCOM 02*, pp. 1587-1596, New York, June 2002.

[25] L. C. Zhong, "Design examples and their models", technical document, the Berkeley Wireless Research Center (BWRC) website, http://bwrc.eecs.berkeley.edu/People/Grad_students/czhong/documents/design.pdf, July 2003.