

"Collaborative" Advanced Radio Spectrum Utilization Working Group - Introduction

Ali Ercan

Berkeley Wireless Research Center

UC Berkeley



- Robust, agile, efficient wireless networks
- Optimal utilization of resources
 - Spectrum
 - Energy
- Supports managed and ad-hoc modes and seamless migration between them
- Collaborative cognitive radio networks – promising technology to achieve these goals
- Our emphasis: **collaboration**

- Collaboration at work!
 - Spectrum sensing
 - Enabling reliable and optimal connectivity – brokerage
 - Collaborative MIMO
- Cognitive Radio Hardware
 - Wideband transceivers
 - Software defined radio
 - 60GHz
 - A/D and D/A converters
- Protocols, signaling, algorithms
- System level implementation

Agenda

- 1-slide introductions of students' work
 - BWRC (Ali Ercan)
 - Connectivity Lab (Sofie Pollin)
 - Wireless Foundations (Rahul Tandra)
- Open discussion



Connectivity Brokerage [A. Ercan]

- Functional entity:
 - Resides anywhere in the network
 - Connects terminals reliably and efficiently
 - Provides seamless migration between infrastructure and ad-hoc modes
 - Supports weak nodes and legacy terminals, necessary signaling
 - Adapts to future standards through programmability
 - Optimizes utilization of the resources and/or cost, under policy rules, rules of engagement, security and quality constraints and resource constraints
- Practical issues
- Test Bed



Direct Waveform Synthesis for Cognitive Radio Transmitter [S. Chen, N. Kim]

- Transmitter Architecture for Direct Waveform Synthesis (DWS)
 - All waveforms are generated in discrete sampled format with DSP enhancement
 - Directly converted by a high speed multi-mode DAC
 - Mostly digital, no mixer/PLL frequency synthesizer for up-conversion and frequency hopping

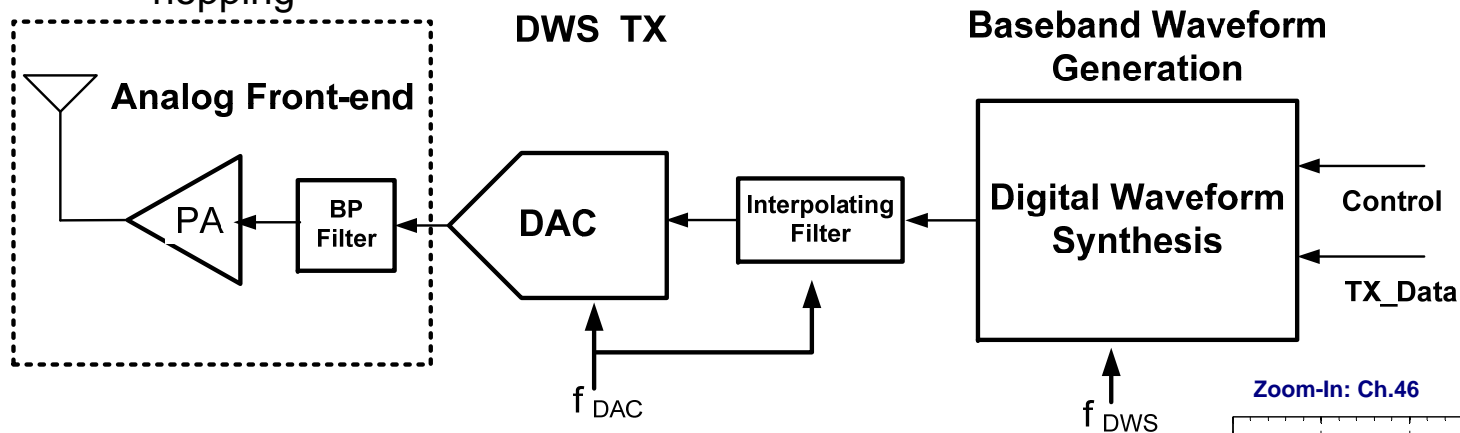

- Synthesized RF Signal in TV Band
 - Target band: 54MHz~862MHz
 - 6MHz BW
 - 16 sub-carriers
 - Sub-carrier spacing: 375 KHz
 - Sub-carrier modulation: BPSK
 - Multi-mode DAC: 10 bit, 600 MS/s

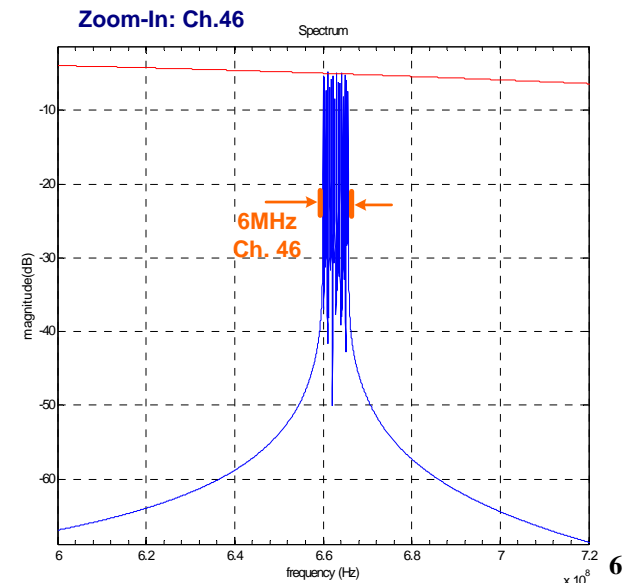

- Advisor : Bora Nikolic
- Current project : Discrete-time sigma-delta RF receiver
- Interest in collaborative communication meetings :
Low-power analog-to-digital interface for cognitive radio-like receivers

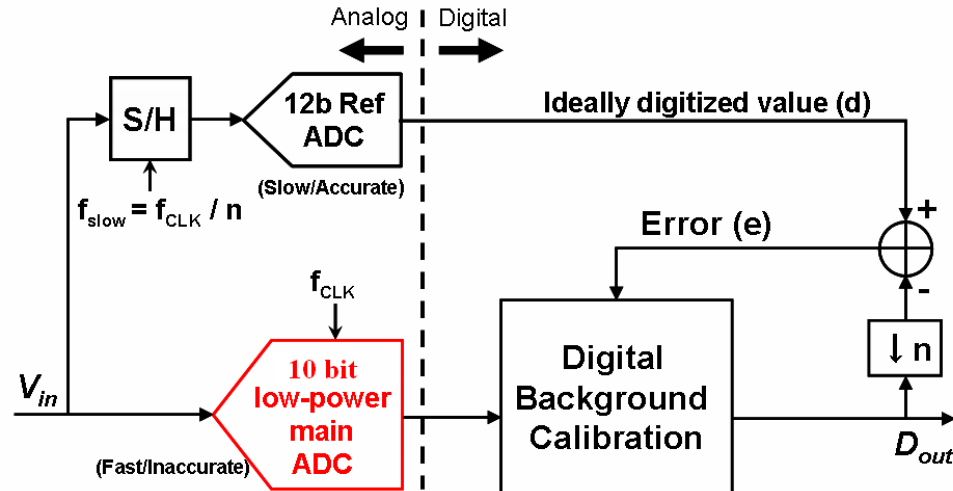

- High speed and low power, but inaccurate pipeline ADC
- Referent ADC slow, low power, but accurate
- Use completely digital background calibration to correct linear sources of errors

Ref.: Yun Chiu, Cheongyuen W. Tsang, Borivoje Nikolić and Paul R. Gray, "Least Mean Square Adaptive Digital Background Calibration of Pipelined Analog-to-Digital Converters", IEEE Trans. Circuits and Systems, Vol. 51, No. 1, January 2004



Implementation issues in Distributed MIMO

- Vinayak Nagpal – advisor Prof. Borivoje Nikolic
- Patrick Machler – advisor Prof. Jan Rabaey

- Studying effects of synchronization errors in Distributed MIMO
- Experimenting with real time implementations of simple decoding schemes like Alamouti with symbol timing recovery.
- Working towards real time implementation of test-bed for distributed VBLAST

60 GHz Research Update

- Cristian Marcu, Debopriyo Chowdhury, Maryam Tabesh, Ali M. Niknejad
- Work in progress
 - Building blocks already demonstrated in 90nm CMOS
 - LNA and Mixer
 - Integrated Receiver with VGA (ISSCC08)
 - Power Amplifier (ISSCC08)
 - Current blocks being designed
 - VCO and PLL
 - PA with integrated driver chain
 - Up conversion Mixer
 - Targeting integration of building blocks into a full transceiver with digital baseband



Transceiver Test-Chip Goals

- Construct a platform for 60 GHz testing
 - Demonstrate high data transfer rates (up to 10 Gbps)
 - Perform channel measurements and channel sounding experiments
- Integrate and characterize complete TX/RX signal path, including high-speed baseband
 - Will help to identify critical components/issues from performance/power dissipation standpoint
- Both goals lead to valuable results for BWRC researchers and for member companies

- Lingkai Kong - Advisor: Elad Alon
- Feed-Forward technique to cancel distortion generated in the main path
- Improve power efficiency

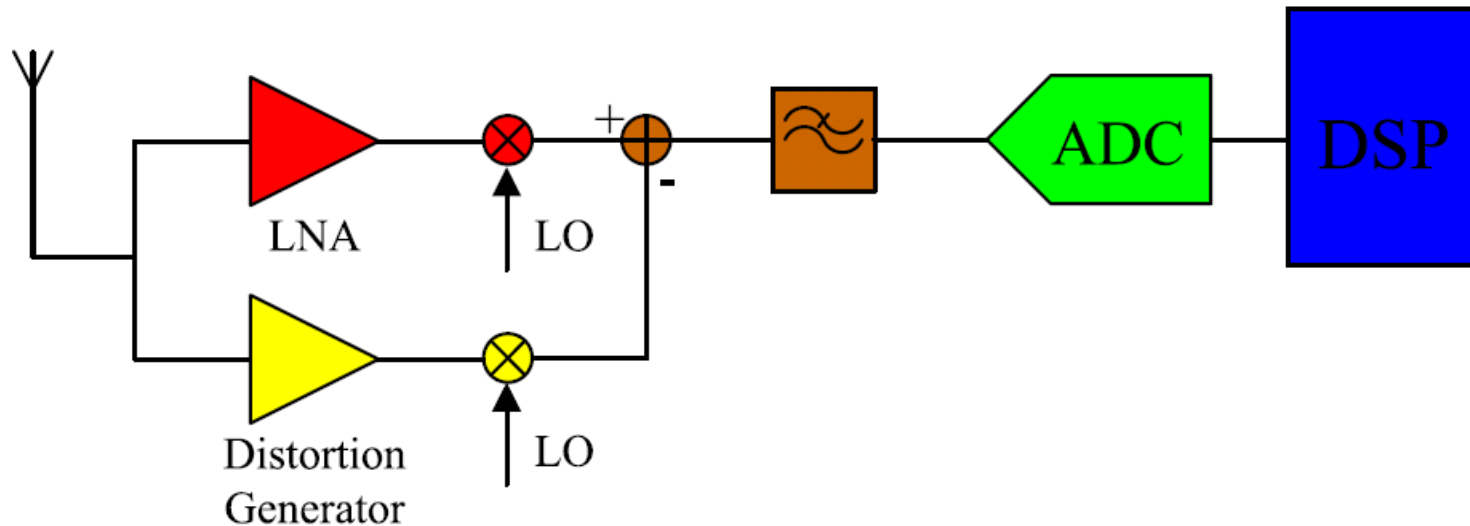

Multi Gb/s 60 GHz Wireless Mobile Transceiver Design

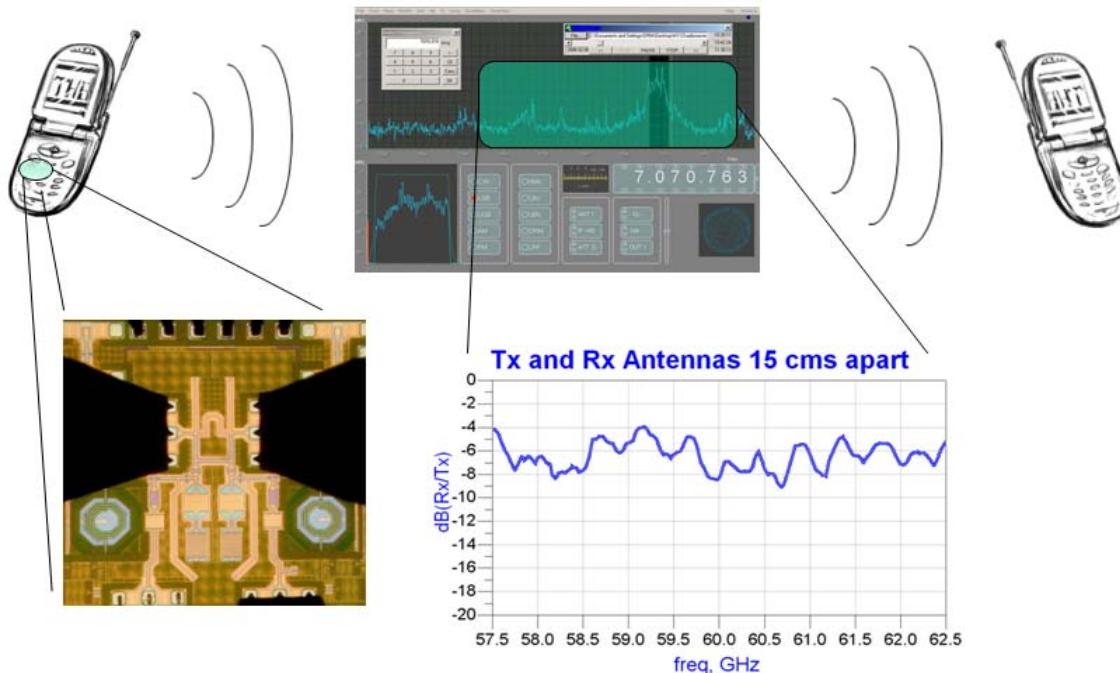

Chintan Thakkar,
Prof. Elad Alon &
Prof. Ali Niknejad

Chip photo courtesy: C. H. Doan, S. Emami, A. M. Niknejad, and R. W. Brodersen, "A 60-GHz down-converting CMOS single-gate mixer," *RFIC Digest of Papers, 2005*

- Optimization of 60 GHz communication system to enable drastically improved energy efficiency for mobile applications
- Accurately measuring 60 GHz channel
- Developing tools for system exploration (e.g. coding, equalization, clock recovery etc)