

UNIVERSITY OF CALIFORNIA AT BERKELEY
College of Engineering
Department of Electrical Engineering and Computer Science

R. W. Brodersen
Johan Vanderhaegen

Homework #7
(Due 10/30/02)

EECS 140
Fall 2002

- 1) Calculate the common mode gain $A_{cm} = v_{out} / v_{in,cm}$ for the circuit shown in figure 1, as a function of the small signal parameters of the transistors. Assume all the transistors to be in saturation.

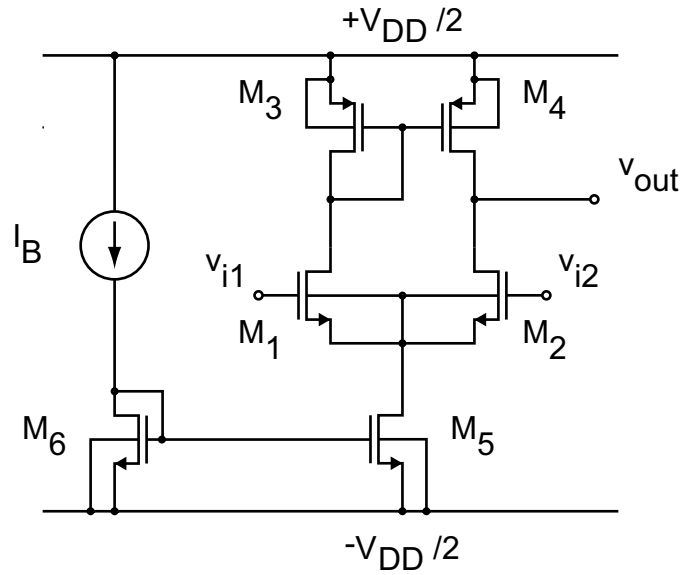

Figure 1.

2)

- a) The transit frequency f_T of a MOSFET is defined as the frequency at which the small signal current gain drops to unity, while the source and drain are held at AC ground.

For the circuit in figure 2, calculate the current gain i_d/i_g as a function of frequency and the small signal parameters of M1. Ignore the effect of C_{gd} . Assume M1 to be in saturation.

Calculate the frequency for which this (approximated) current gain becomes 1.

- b) Express the result as a function of W , L , C_{ox} , μ_0 , $V_{GS}-V_T$ (ignore the overlap part C_{gs0} of C_{gs}).

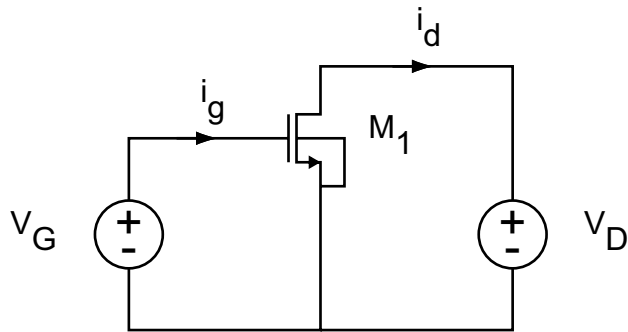

Figure 2.