

University of California
Berkeley

College of Engineering
Department of Electrical Engineering
and Computer Science

Robert W. Brodersen

EECS140

Analog Circuit Design

Lectures
on
FREQUENCY RESPONSE

Bode Plots

FR-1

Solve impedance network transfer function.

$$H(\omega) = \frac{V_{OUT}(\omega)}{V_{IN}(\omega)} \quad (H(\omega), V_{out}(\omega) \text{ \& } V_{in}(\omega) \text{ are phasors})$$

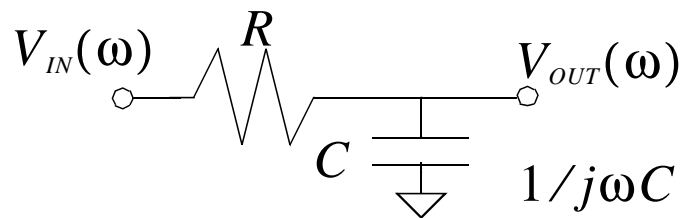

$$H(\omega) = \frac{V_{OUT}(\omega)}{V_{IN}(\omega)} = \frac{1/j\omega C}{R + 1/j\omega C}$$

$$H(\omega) = \frac{1/j\omega C}{1 + j\omega RC}$$

Convert $H(\omega)$ to polar coordinates, $|H(\omega)| < \theta$

$$|H(\omega)| = [H(\omega)(H^*(\omega))]^{\frac{1}{2}}$$

$$\theta = \text{atan} \left\{ \frac{I_m\{H(\omega)\}}{R_e\{H(\omega)\}} \right\}$$

$$\text{IF } H(\omega) = \frac{N(\omega)}{D(\omega)} \text{ then}$$

$$R_e \cdot \{H(\omega)\} = R_e \cdot \{N(\omega) \cdot D^*(\omega)\}$$

$$I_M \cdot \{H(\omega)\} = I_M \cdot \{N(\omega) \cdot D^*(\omega)\}$$

Bode Plots (Cont.)

$$\begin{aligned} (H(\omega) \cdot H^*(\omega))^{1/2} &= \left(\frac{1}{1 + j\omega RC} \right) \cdot \left(\frac{1}{1 - j\omega RC} \right) \\ &= \left(\frac{1}{1 + (\omega RC)^2} \right)^{1/2} = \left(\frac{1}{1 + \left(\frac{\omega}{\omega_{3dB}} \right)^2} \right)^{1/2} \end{aligned}$$

Bode Plot Magnitude $|H(\omega)|_{dB} = 20 \cdot \log |H(\omega)|$

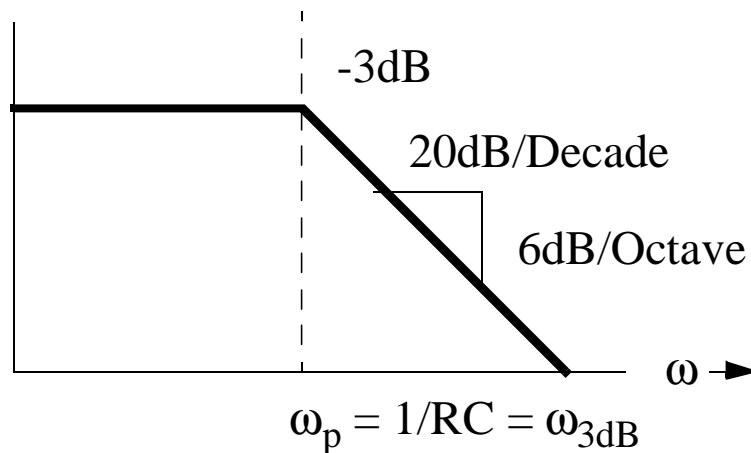

$$\omega \gg \omega_{3dB}$$

$$|H(\omega)| \approx \left[\frac{1}{\left(\frac{\omega}{\omega_{3dB}} \right)^2} \right]^{1/2} = \frac{\omega_{3dB}}{\omega}$$

6dB/Octave - drops by 2 every time frequency doubles

Bode Plots (Cont.)

FR-3

$$H(\omega) = \frac{1}{1 + j\frac{\omega}{\omega_{3dB}}} = |H(\omega)| \cdot \exp(j\theta(\omega))$$

$$H(\omega) = \frac{1}{1 + j\frac{\omega}{\omega_{3dB}}} \cdot \frac{\left(1 - j\frac{\omega}{\omega_{3dB}}\right)}{1 - j\frac{\omega}{\omega_{3dB}}}$$

$$= \frac{1 - j\frac{\omega}{\omega_{3dB}}}{1 + \left(\frac{\omega}{\omega_{3dB}}\right)^2}$$

$$\theta(\omega) = \text{atan} \left\{ \frac{I_m H(\omega)}{R_e H(\omega)} \right\}$$

Bode Plots (Cont.)

FR-4

$$\operatorname{Re}\{H(\omega)\} = \frac{1}{1 + \left(\frac{\omega}{\omega_{3dB}}\right)^2}$$

$$\operatorname{Im}\{H(\omega)\} = \frac{-\left(\frac{\omega}{\omega_{3dB}}\right)}{1 + \left(\frac{\omega}{\omega_{3dB}}\right)^2}$$

$$\theta(\omega) = \arctan\left\{-\frac{\omega}{\omega_{3dB}}\right\}$$

$$= -\arctan\left\{\frac{\omega}{\omega_{3dB}}\right\}$$

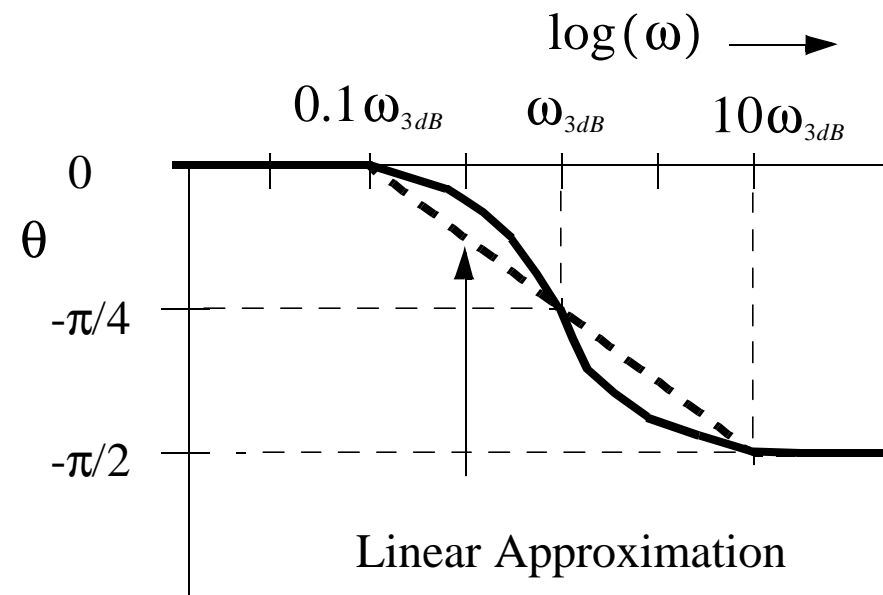

FR-5

Bode Plots (Cont.)

0 Phase
Magnitude

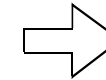
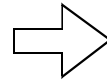
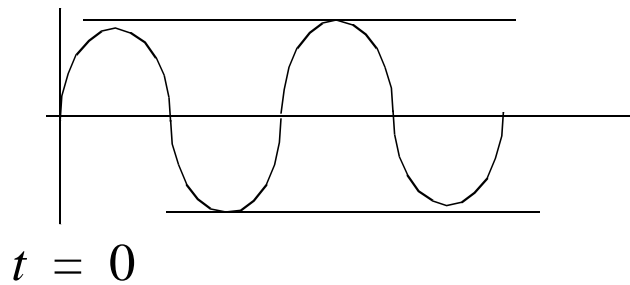

90 Phase difference
Magnitude Change

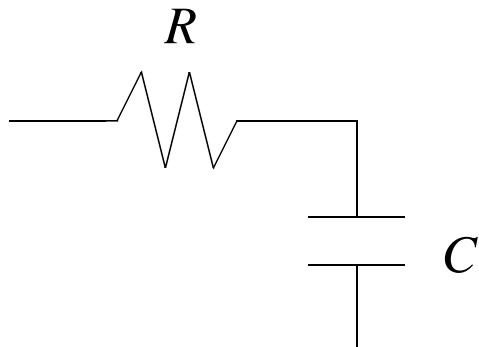
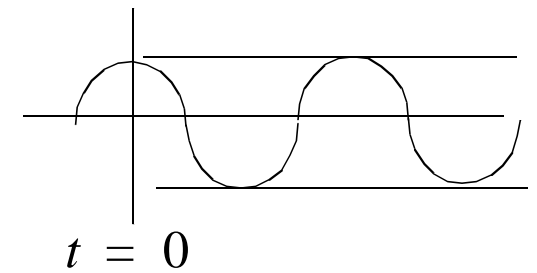

$$H(\omega) = \frac{1}{1 + j\omega RC}$$

$$|H(\omega)| = (H(\omega) \cdot H^*(\omega))^{1/2}$$

Bode Plots (Cont.)

FR-6

1 Pole Summary

$$H(\omega) = \frac{1}{1 + j\frac{\omega}{\omega_{3dB}}}$$

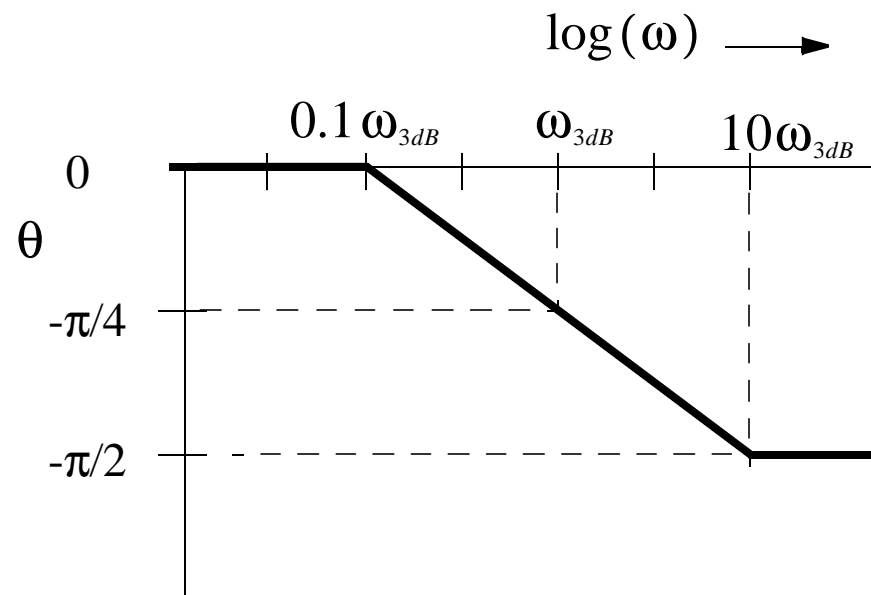
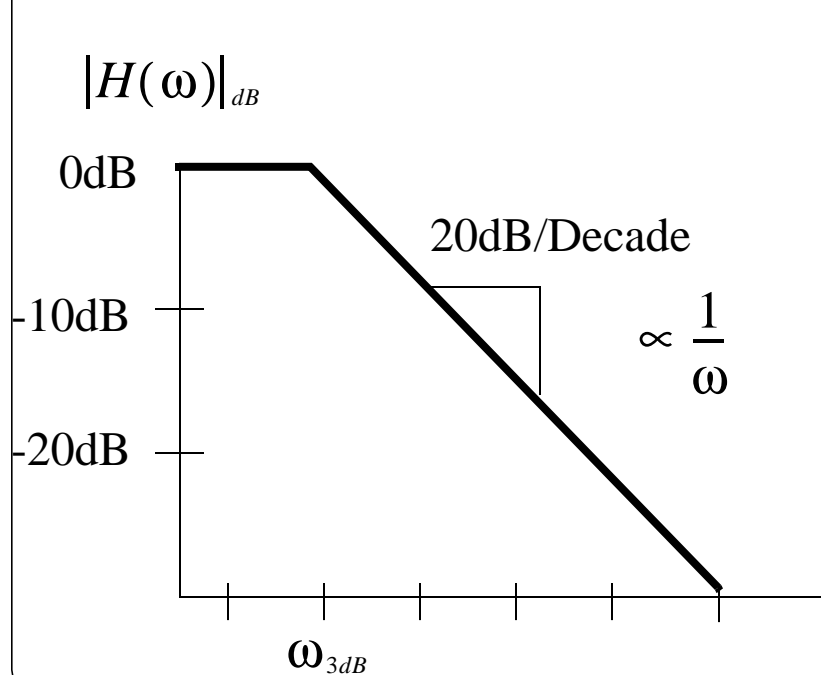
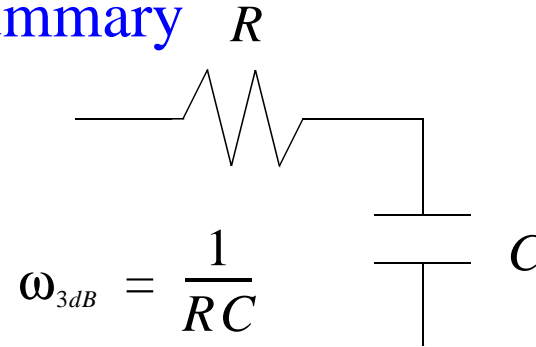

FR-7

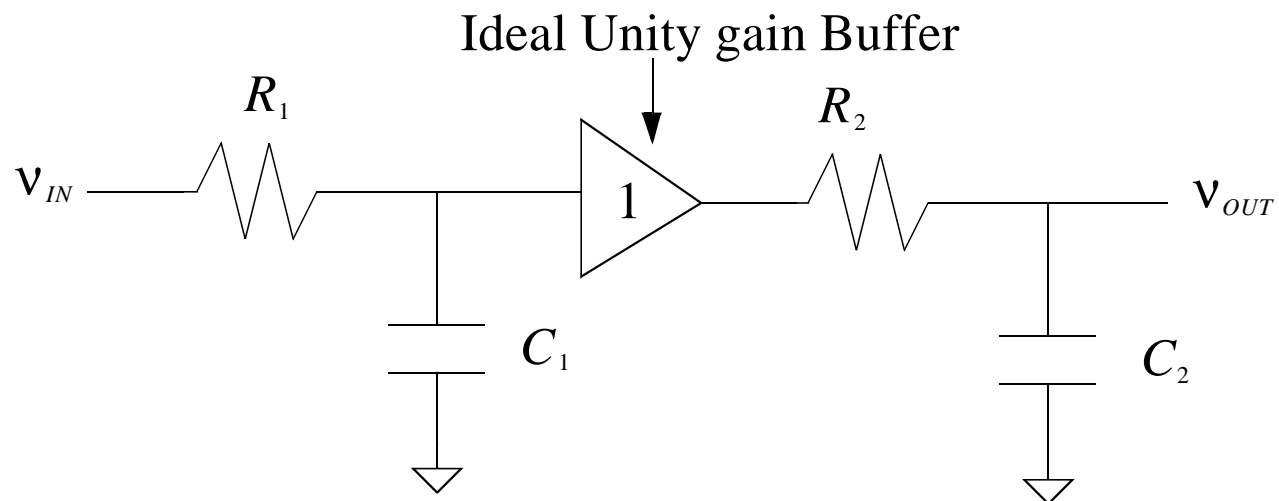
Bode Plots (Cont.)**2 Poles**

Two Poles:

Bode Plots (Cont.)

FR-8

$$H(\omega) = \left(\frac{1}{1 + j\frac{\omega}{\omega_{p1}}} \right) \cdot \left(\frac{1}{1 + j\frac{\omega}{\omega_{p2}}} \right) = H_{\omega_{p1}}(\omega) \cdot H_{\omega_{p2}}(\omega)$$

$$\begin{aligned} 20 \cdot \log |H(\omega)| &= 20 \cdot \log (|H_{\omega_{p1}}(\omega)| \cdot |H_{\omega_{p2}}(\omega)|) \\ &= 20 \cdot \log |H_{\omega_{p1}}(\omega)| + 20 \cdot \log |H_{\omega_{p2}}(\omega)| \end{aligned}$$

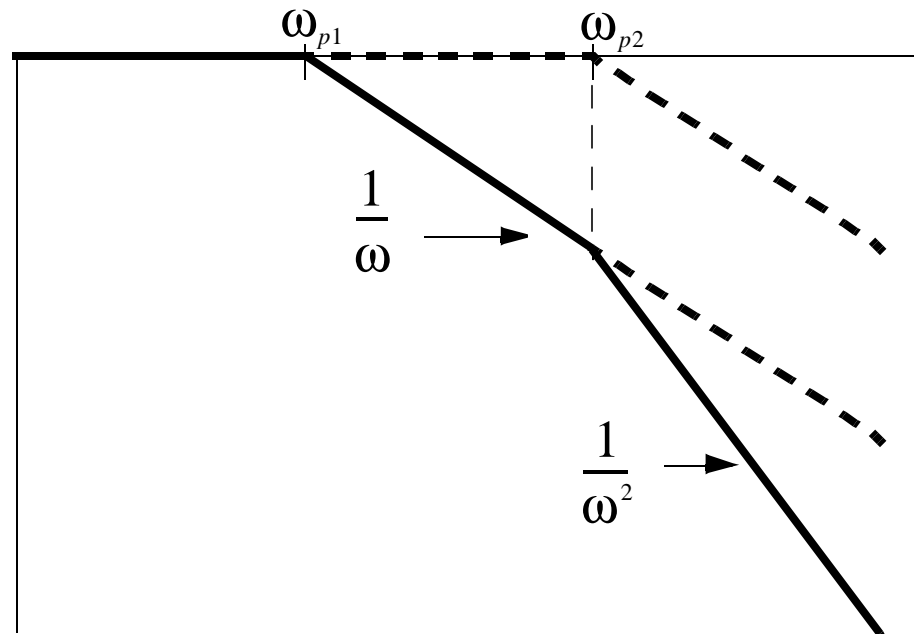

Bode Plots (Cont.)

FR-9

$$\begin{aligned}
 H(\omega) &= [|H_{\omega_{p1}}| \cdot \exp(j\theta_{\omega_{p1}})] \cdot [|H_{\omega_{p2}}| \cdot \exp(j\theta_{\omega_{p2}})] \\
 &= |H_{\omega_{p1}}| \cdot |H_{\omega_{p2}}| \cdot \exp(j[\theta_{\omega_{p1}} + \theta_{\omega_{p2}}]) \\
 &= |H(\omega)| \cdot \exp(j\theta(\omega))
 \end{aligned}$$

$$\theta(\omega) = \theta_{\omega_{p1}} + \theta_{\omega_{p2}}$$

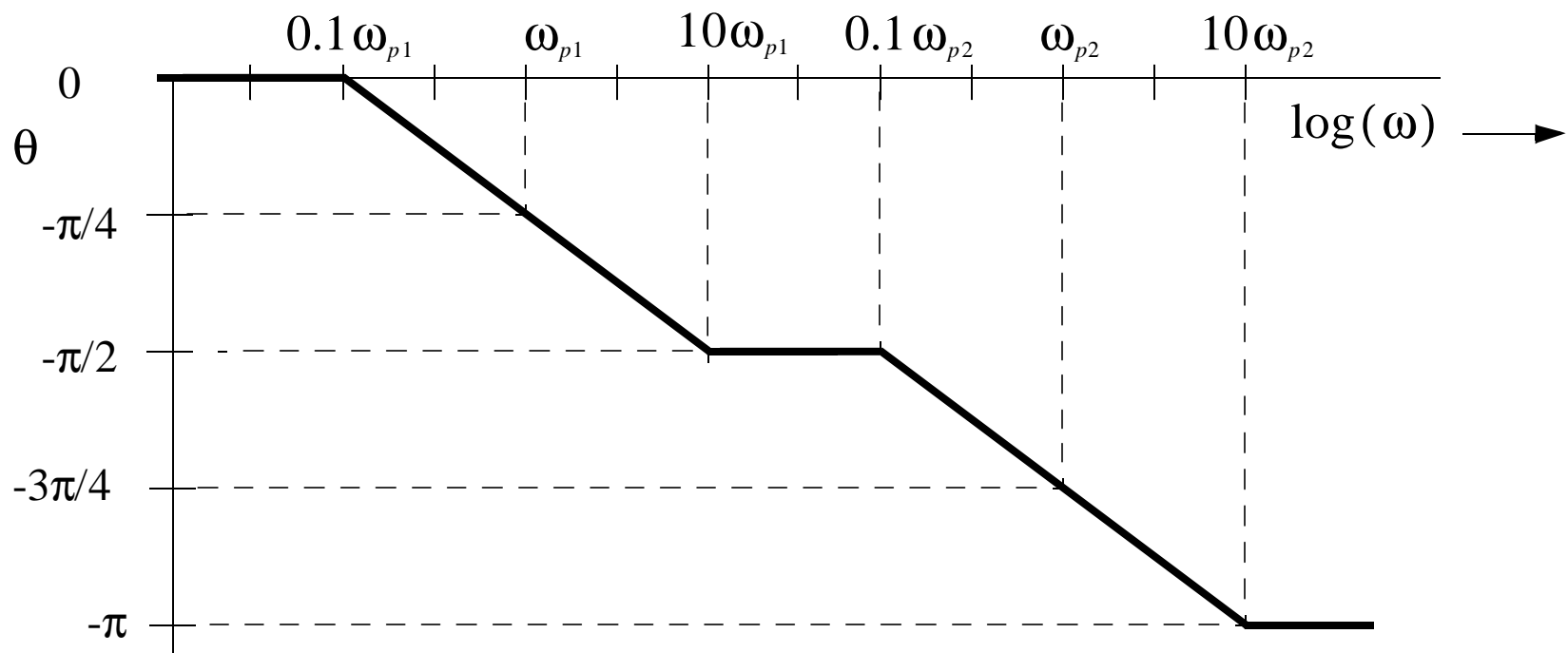

Bode Plots (Cont.)

FR-10

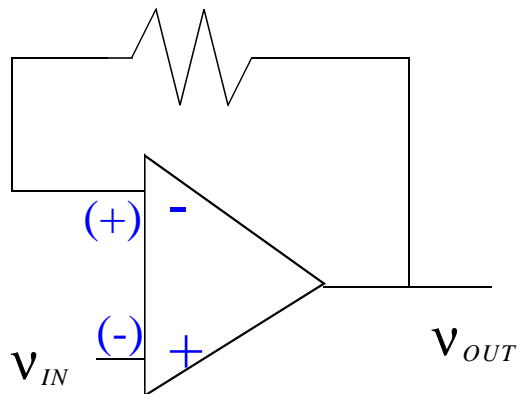
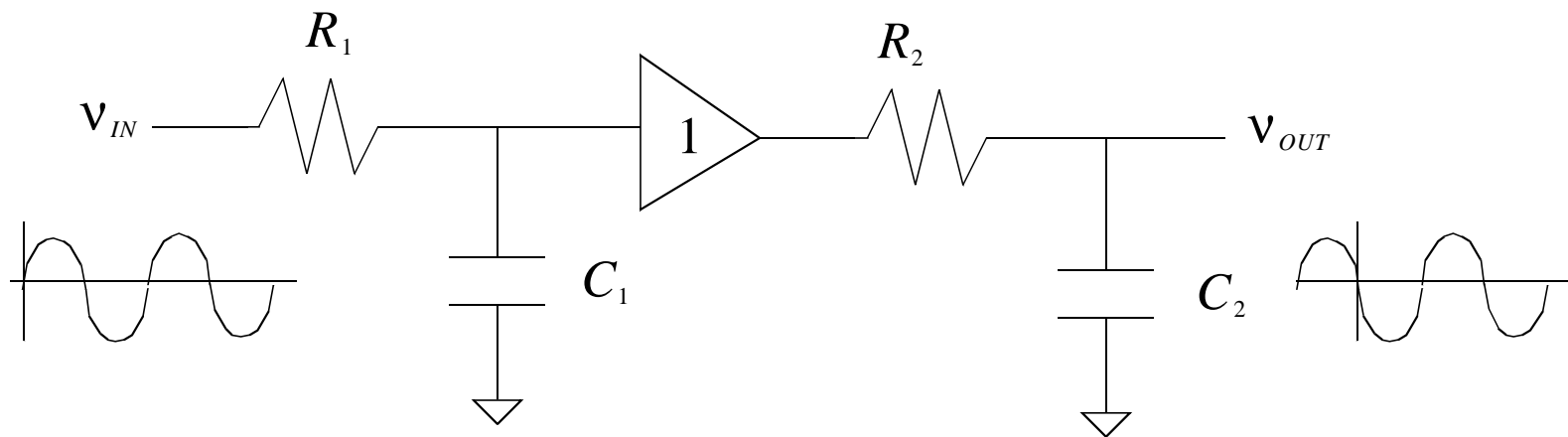

If we have 180 degree phase shift we have a problem.
 The negative feedback will turn into positive feedback.
 Can't have positive feedback in a loop with gain > 1

Bode Plots (Cont.)

FR-11

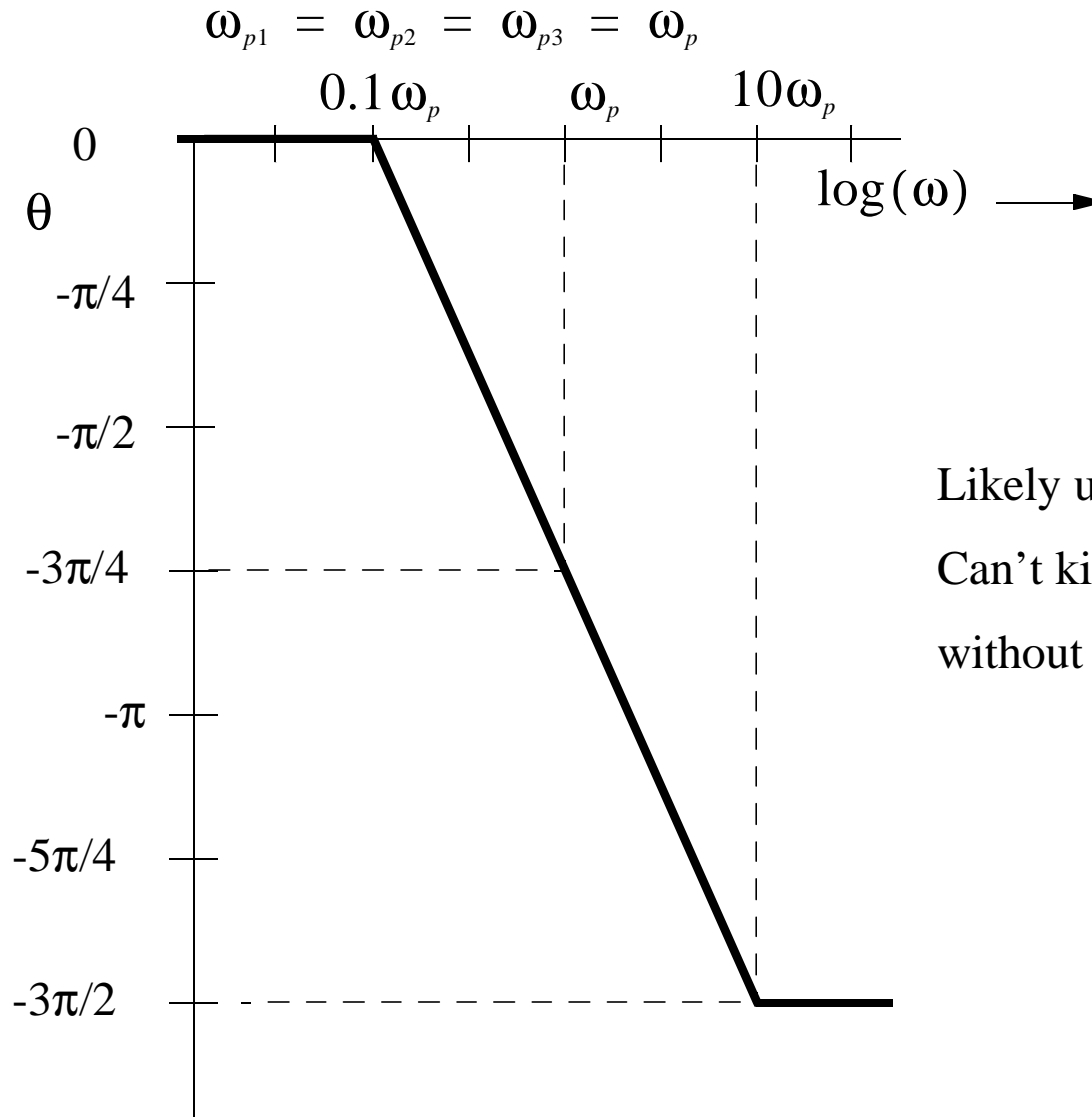

3 poles on top
of each other

Likely unstable circuit

Can't kill gain here

without adding phase shift.

Bode Plots (Cont.)

FR-12

Zero at zero frequency, pole at $1/RC$

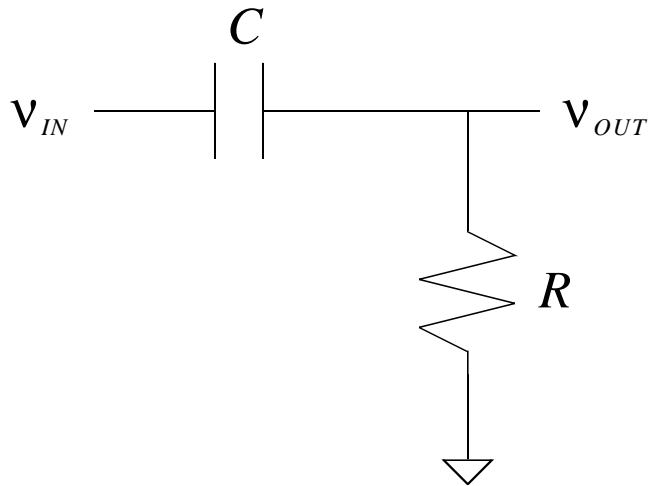

$$\frac{R}{R + \frac{1}{j\omega C}} = \frac{j\omega RC}{1 + j\omega RC} = \frac{j\omega RC}{1 + j\frac{\omega}{\frac{1}{RC}}}$$

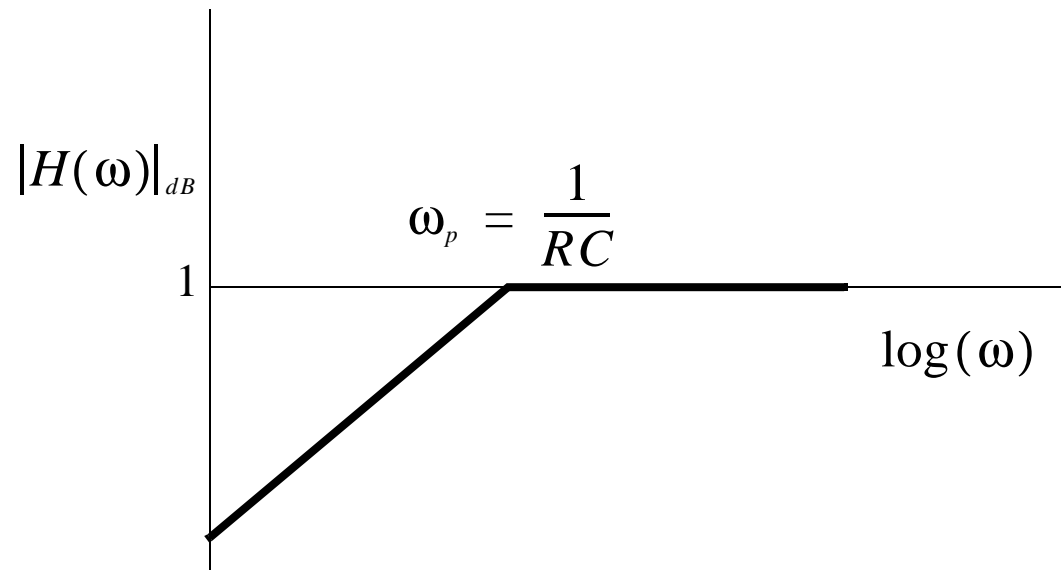

Single Zero at ω_z

FR-13

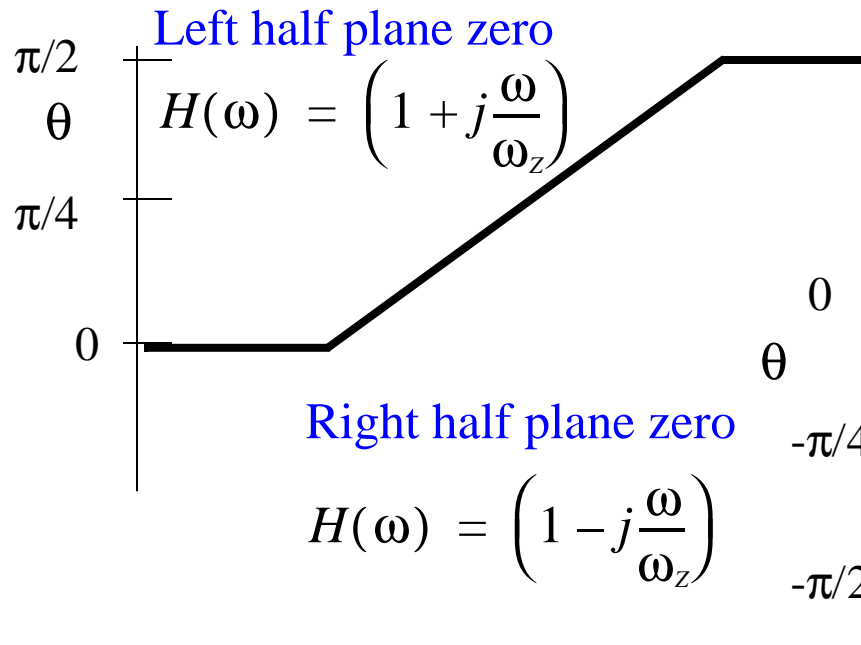

$$\theta = \arctan\left(\frac{\omega}{\omega_z}\right)$$

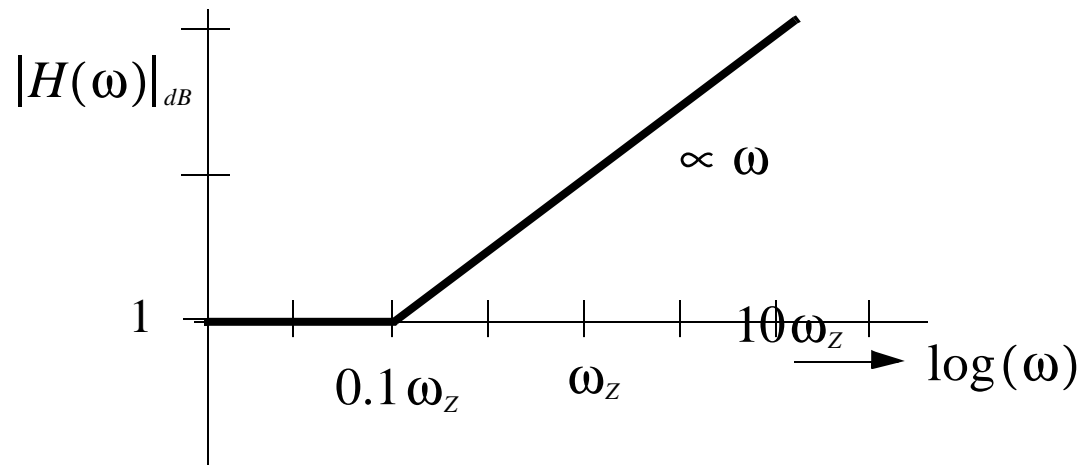
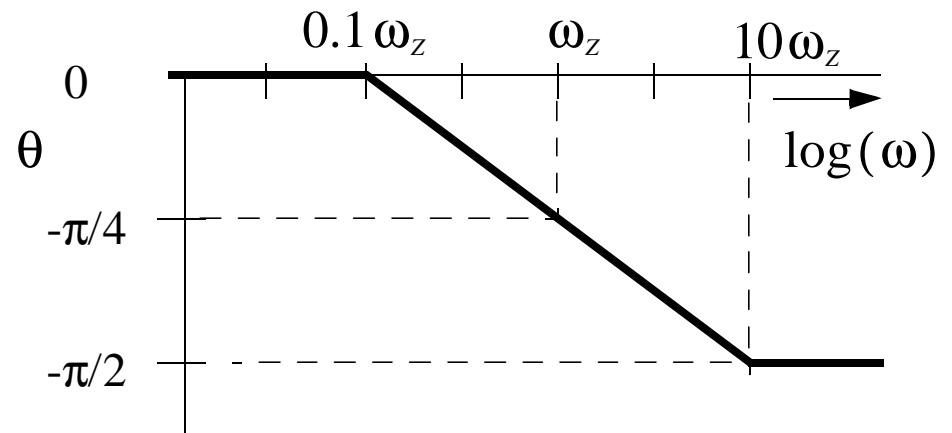

For both:

$$|H(\omega)| = \left(1 + \left(\frac{\omega}{\omega_z}\right)^2\right)^{1/2}$$

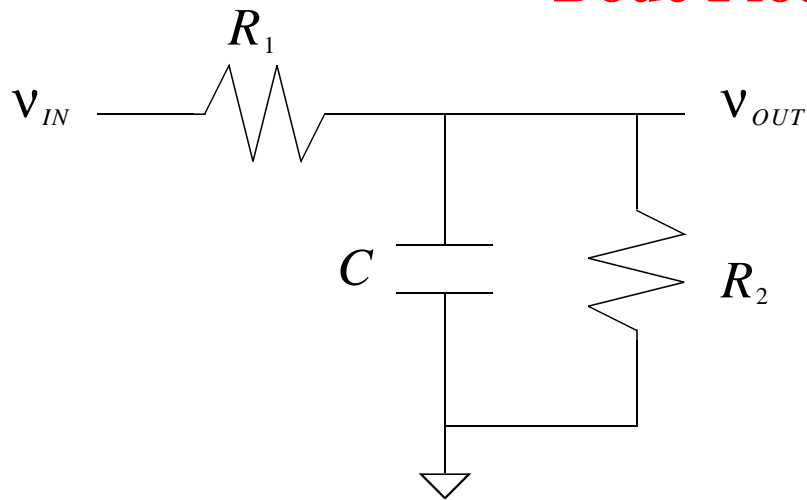
Bode Plots (Cont.)**1 Pole**

$$H(\omega) = \left(\frac{R_2}{R_1 + R_2} \right) \cdot \frac{1}{1 + j\omega(R_1 \parallel R_2)C}$$

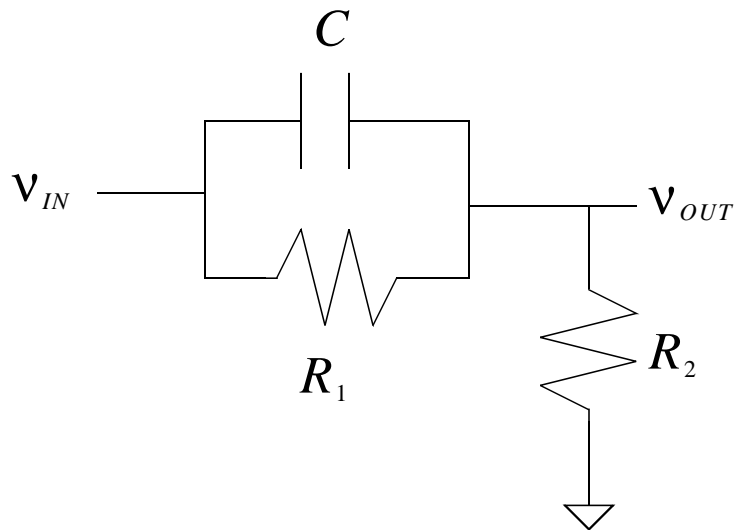
**1 Pole, 1 Zero**

$$H(\omega) = \left(\frac{R_2}{R_1 + R_2} \right) \cdot \frac{1 + j\omega R_1 C}{1 + j\omega(R_1 \parallel R_2)C}$$

Bode Plots (Cont.)

1 Pole, 1 Zero

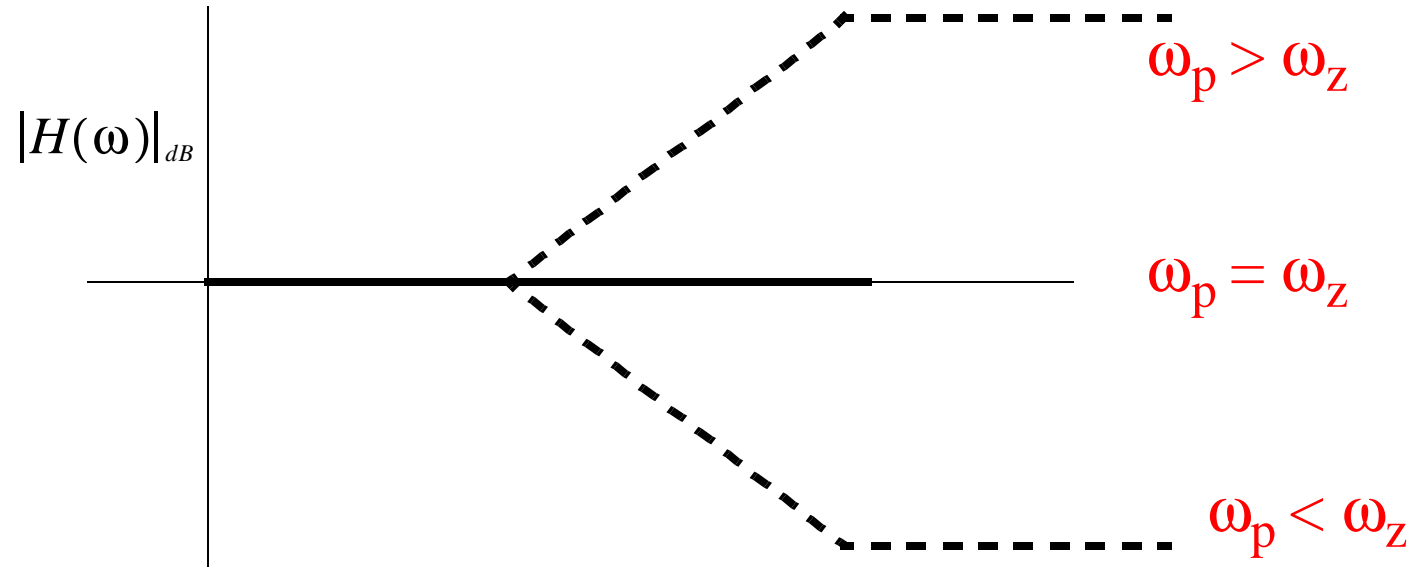

$$H(\omega) = \frac{1 + j\frac{\omega}{\omega_z}}{1 + j\frac{\omega}{\omega_p}}$$

Capacitances

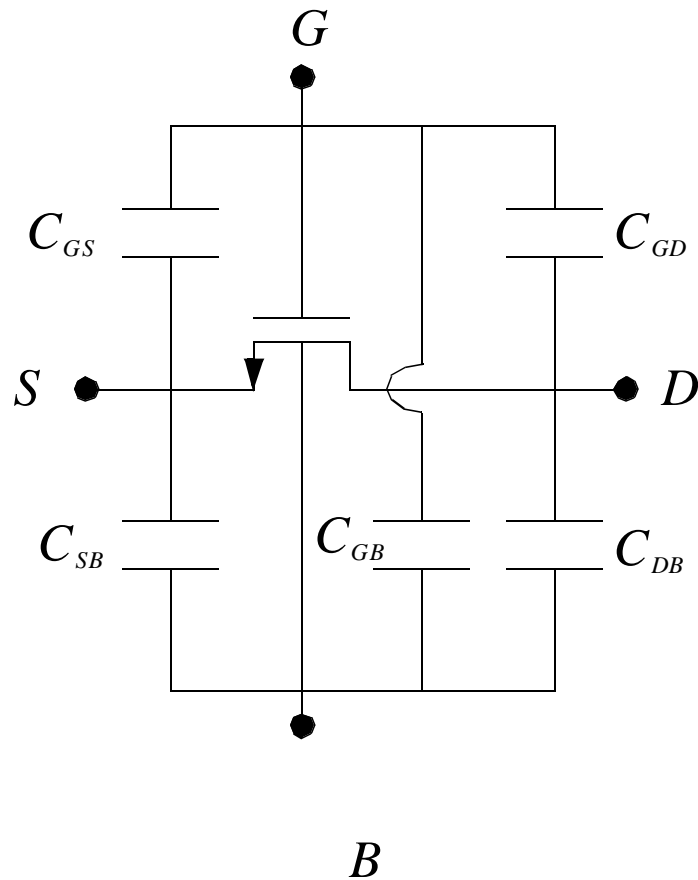

$$C_{ox} = \frac{\epsilon_{SiO_2}}{t_{ox}} = 0.1 \frac{fF}{\mu^2} = 10^{-4} \frac{F}{m^2}$$

$$C_{GSO} = 5 \times 10^{-10} \frac{F}{m}$$

$$C_{GDO} = 5 \times 10^{-10} \frac{F}{m}$$

$$C_{GBO} = 4 \times 10^{-10} \frac{F}{m}$$

$$C_J = 10^{-4} \frac{F}{m^2}$$

$$PB = \phi_B = 0.8V$$

Capacitances (Cont.)

FR-17

Sat :

$$C_{GS} = \frac{2}{3} \cdot C_{ox} \cdot L \cdot W + CGSO \cdot W$$

$$C_{GD} = CGDO \cdot W$$

$$C_{SB} = \frac{CJ \cdot AS}{\left(1 + \frac{V_{BS}}{PB}\right)^{MJ}} + \frac{CJSW \cdot PS}{\left(1 + \frac{V_{BS}}{PB}\right)^{MJSW}}$$

$$C_{GB} = CGBO \cdot L$$

PS = Perimeter of Source

AS = Area of Source

$CGBO \equiv$ Capacitance of gate to bulk overlap

Linear :

$$C_{GS} = \frac{C_{ox} \cdot L \cdot W}{2} + CGSO \cdot W$$

$$C_{GD} = \frac{C_{ox} \cdot L \cdot W}{2} + CGDO \cdot W$$

(similar for C_{DB})

$$MJ = \frac{1}{2} \text{ (default)}$$

$$MJSW = 3 \text{ (default)}$$

Capacitances (Cont.)

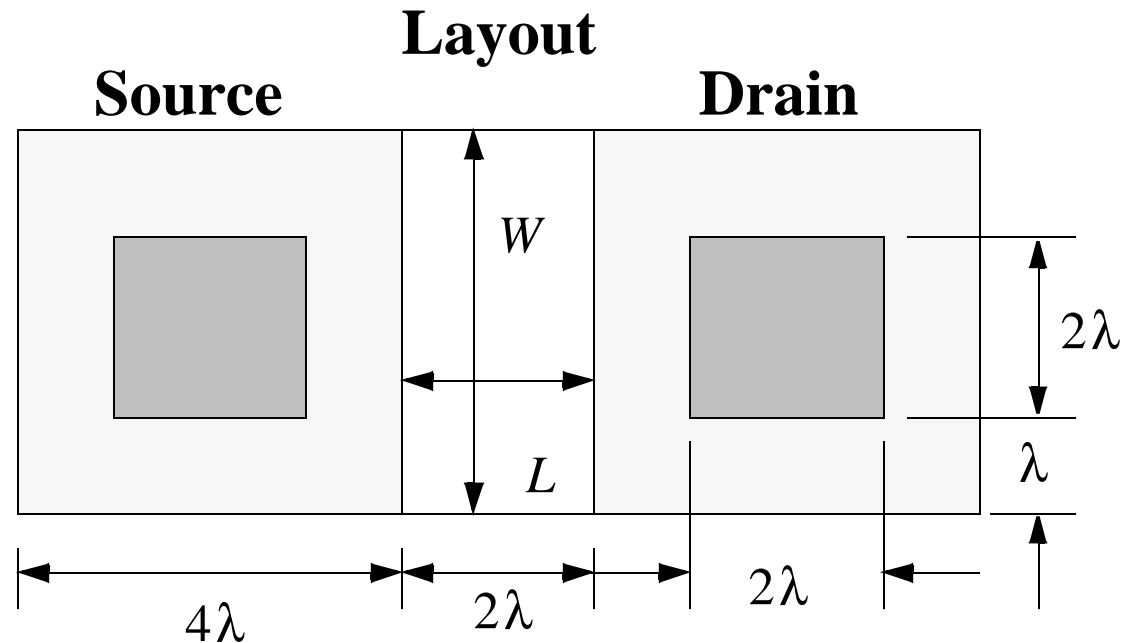

(Minimum size device, $W/L = 2$)

$$\text{Area of Source} = AS = 4\lambda \cdot W$$

$$\text{Area of Drain} = AD = AS$$

$$\text{Perimeter of Source} = PS = 8\lambda + W$$

Miller Approximation

FR-20

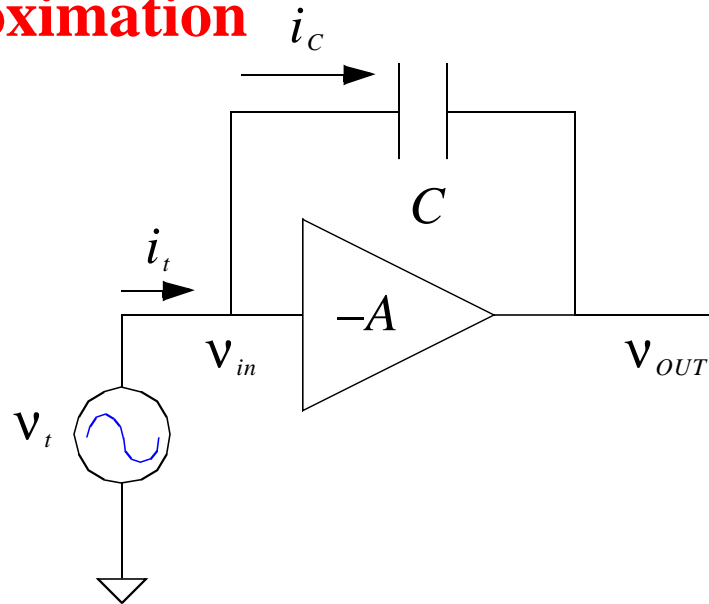

$$v_{OUT} = -A \cdot v_{in}$$

$$i_c = C \cdot \frac{d}{dt}(v_{in} - v_{OUT}) = C \cdot \frac{d}{dt}(v_{in} + A \cdot v_{OUT}) = C \cdot (1 + A) \cdot \frac{dv_{in}}{dt}$$

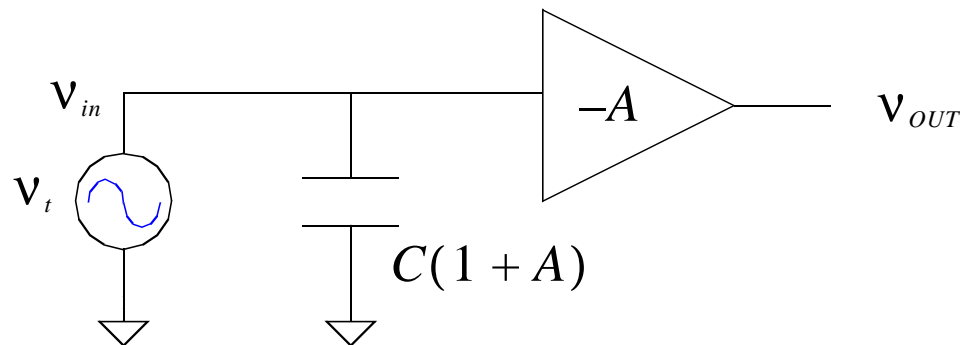

Miller Approximation (Cont.)

FR-21

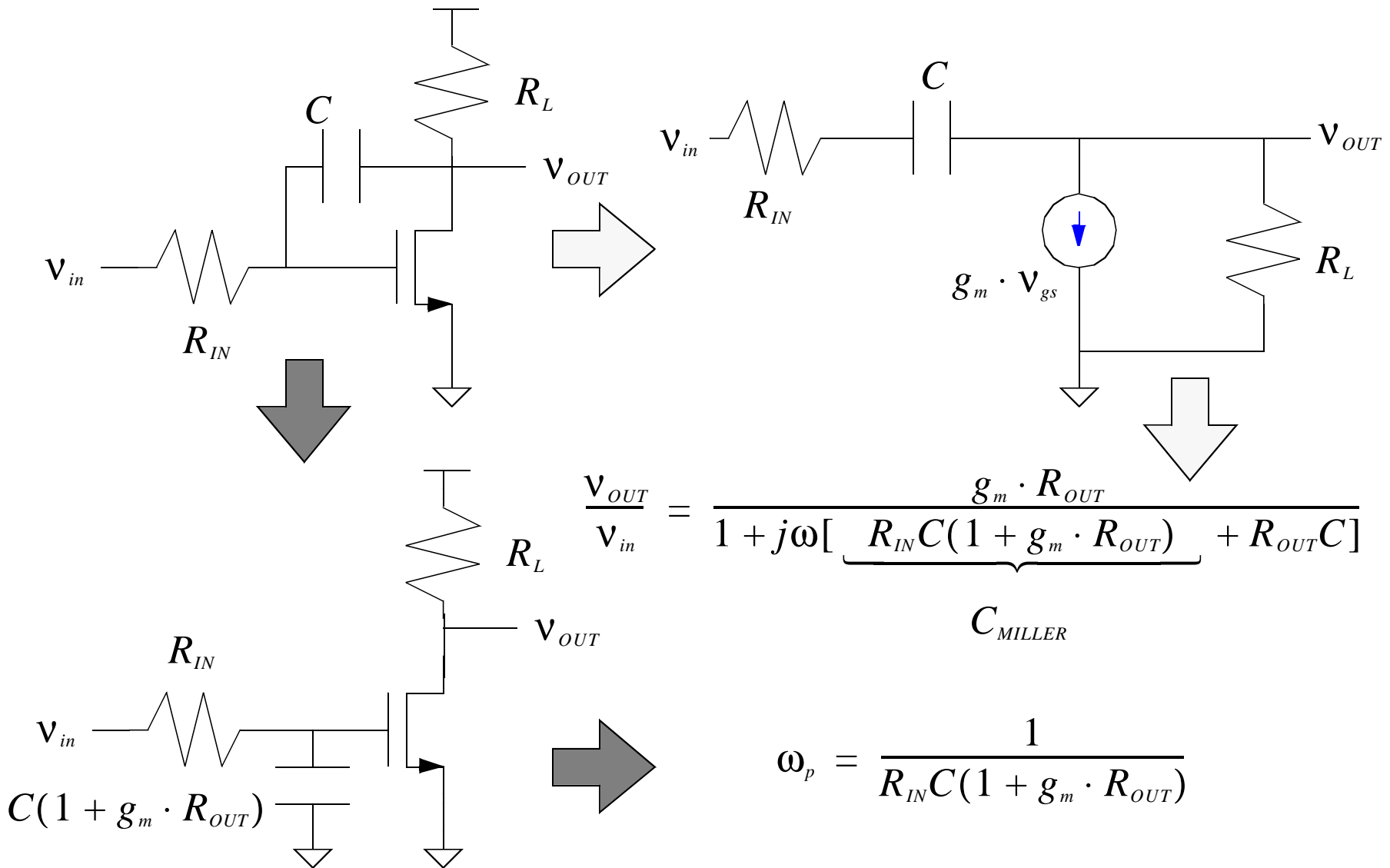

Inverter

FR-22

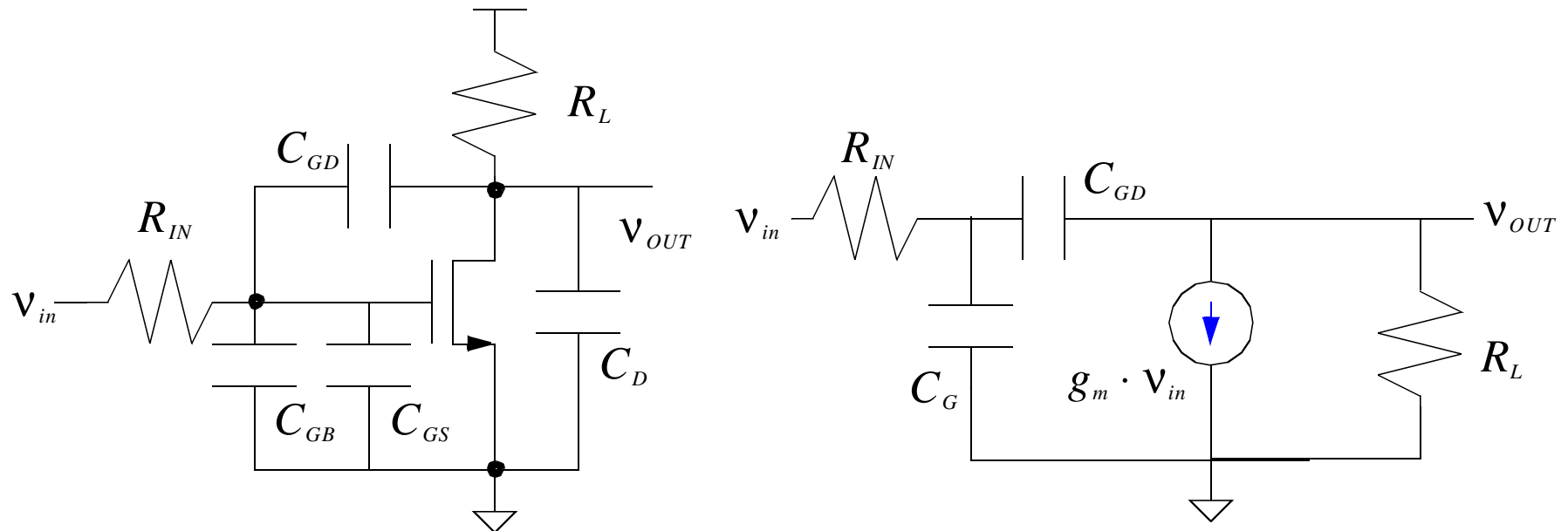

$$R_{OUT} = R_L \parallel r_o$$

$$C_G = C_{GB} + C_{GS}$$

C_D ignored (not usually possible)

Inverter (Cont.)

FR-23

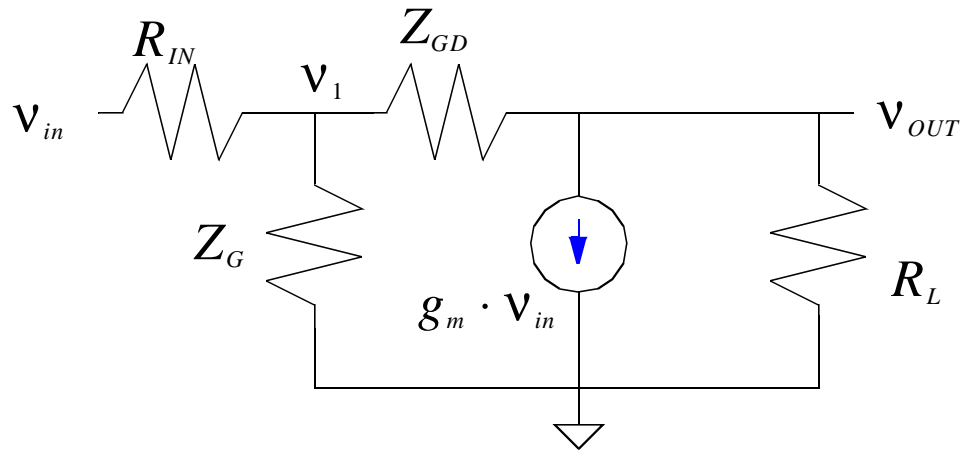

$$\frac{v_1 - v_{in}}{R_{IN}} + \frac{v_1}{Z_G} + \frac{v_1 - v_{OUT}}{Z_{GD}} = 0$$

$$\frac{v_{OUT}}{v_{in}} = -g_m \cdot R_{OUT} \cdot \frac{\left(1 - \frac{C_{GD}}{g_m}\right)}{1 + j\omega \{ [C_{GD}(1 + g_m \cdot R_L) + C_G] \cdot R_{IN} + R_L C_{GD} \} - \omega^2 R_{OUT} R_{IN} C_G C_{GD}}$$

$$= \frac{\left(1 - j\omega \frac{C_{GD}}{g_m}\right)}{\left(1 + j\frac{\omega}{\omega_{p1}}\right) \cdot \left(1 + j\frac{\omega}{\omega_{p2}}\right)} = \frac{\left(1 - j\omega \frac{C_{GD}}{g_m}\right)}{1 + j\omega \left(\frac{1}{\omega_{p1}} + \frac{1}{\omega_{p2}}\right) - \omega^2 \frac{1}{\omega_{p1} \omega_{p2}}}$$

Inverter (Cont.)

FR-24

$$\omega_{p1} = -\frac{1}{R_{IN} \cdot [C_G + \underbrace{C_{GD}(1 + g_m R_{OUT})}_{C_{MILLER}}] + R_L C_{GD}}$$

$$\omega_{p2} = -\frac{1}{R_{OUT} C_{GD}} - \frac{1}{\left(R_{OUT} \parallel R_{IN} \parallel \frac{1}{g_m}\right) C_G}$$

$$\omega_z = \frac{g_m}{C_{GD}}$$

$$H(\omega) = \frac{\left(1 + j\frac{\omega}{\omega_z}\right)}{\left(1 + j\frac{\omega}{\omega_{p1}}\right) \cdot \left(1 + j\frac{\omega}{\omega_{p2}}\right)}$$

Inverter (Cont.)

FR-25

$$H(\omega) = \frac{\left(1 + j\frac{\omega}{\omega_z}\right)}{\left(1 + j\frac{\omega}{\omega_{p1}}\right) \cdot \left(1 + j\frac{\omega}{\omega_{p2}}\right)}$$

$$H(s) = \frac{\left(1 - \frac{s}{s_z}\right)}{\left(1 - \frac{s}{s_{p1}}\right) \cdot \left(1 - \frac{s}{s_{p2}}\right)}$$

$$s_z = -j\omega_z$$

$$s_{p1} = -j\omega_{p1}$$

$$s_{p2} = -j\omega_{p2}$$

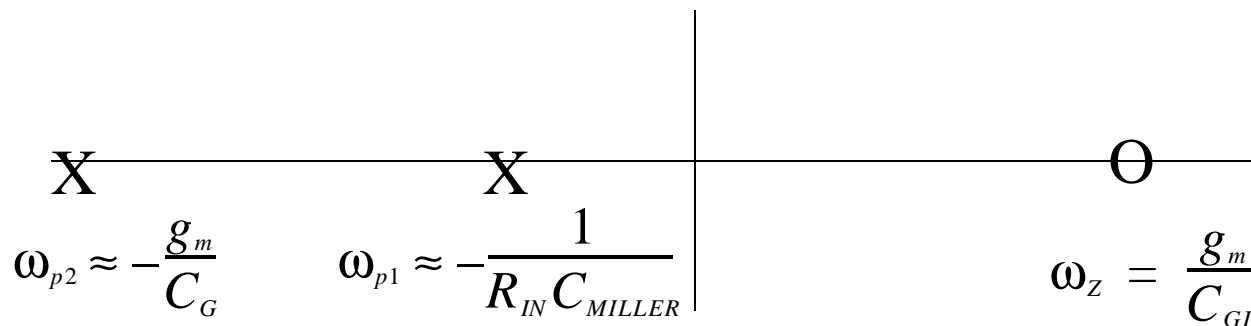

Inverter (Cont.)

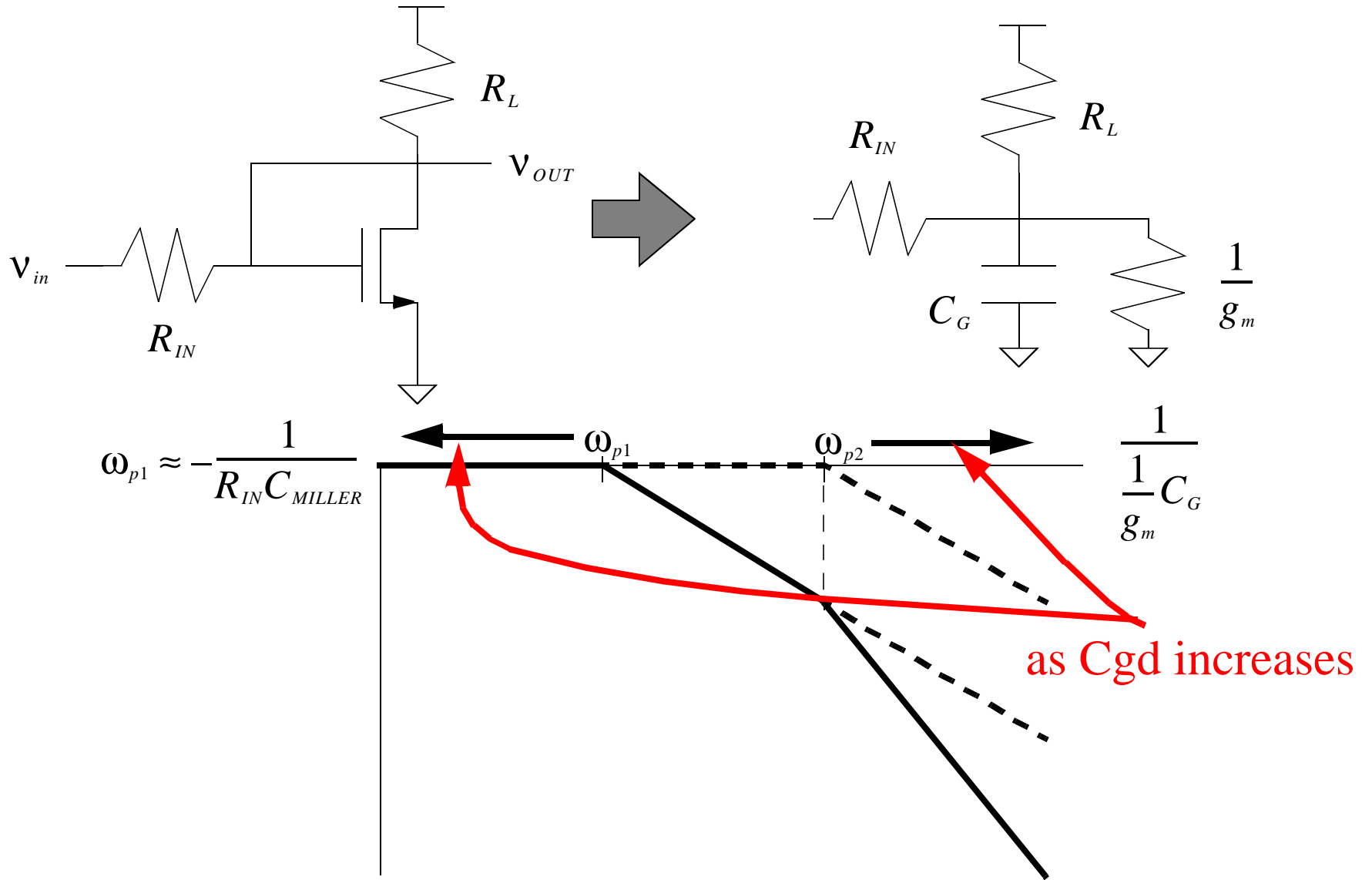

Inverter (Cont.)

FR-27

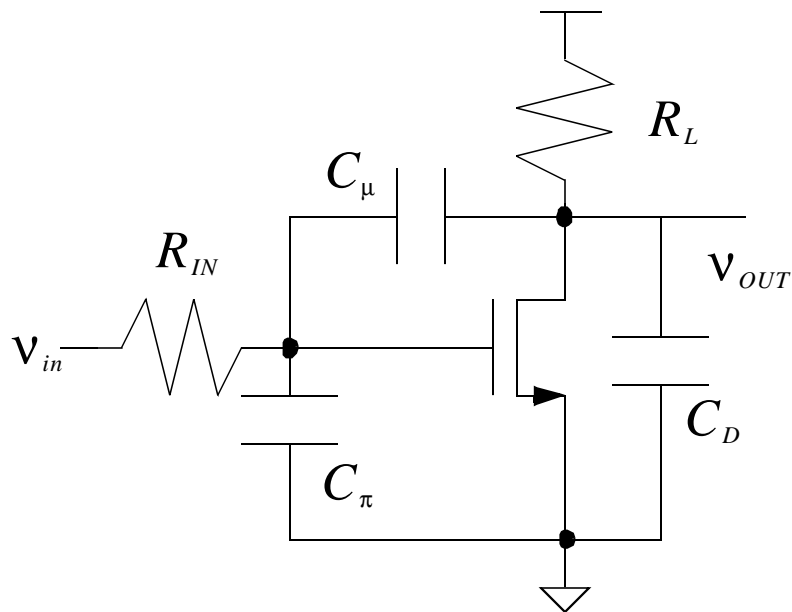

$$R_{OUT} = R_L \parallel r_o$$

Case 1 (Miller Capacitance not important) :

$$R_{IN} C_{\pi}, R_{OUT} C_D \gg R_{IN} \cdot \underbrace{(1 + g_m R_{OUT}) C_{\mu}}_{C_{MILLER}}$$

$$\omega_{p1} = \frac{1}{R_{IN} C_{\pi}}$$

$$\omega_{p2} = \frac{1}{R_{OUT} C_D}$$

Inverter (Cont.)

FR-28

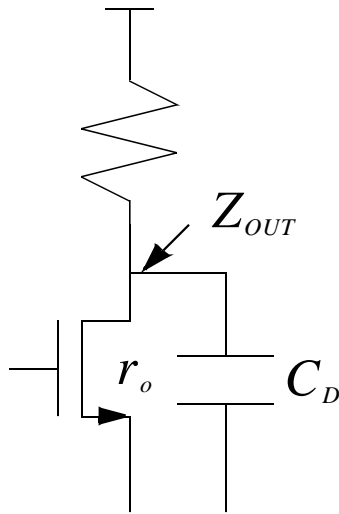

$$Z_{OUT} = R_L \parallel r_o \parallel \frac{1}{j\omega C_D}$$

$$= R_{OUT} \parallel \frac{1}{j\omega C_D}$$

$$A_v = -g_m \cdot Z_{OUT} = -g_m \cdot \frac{\frac{R_{OUT}}{j\omega C_D}}{R_{OUT} + \frac{1}{j\omega C_D}} = -g_m \cdot \frac{R_{OUT}}{1 + j\omega R_{OUT} C_D}$$

$$\omega_p = \frac{1}{R_{OUT} C_D}$$

Inverter (Cont.)

FR-29

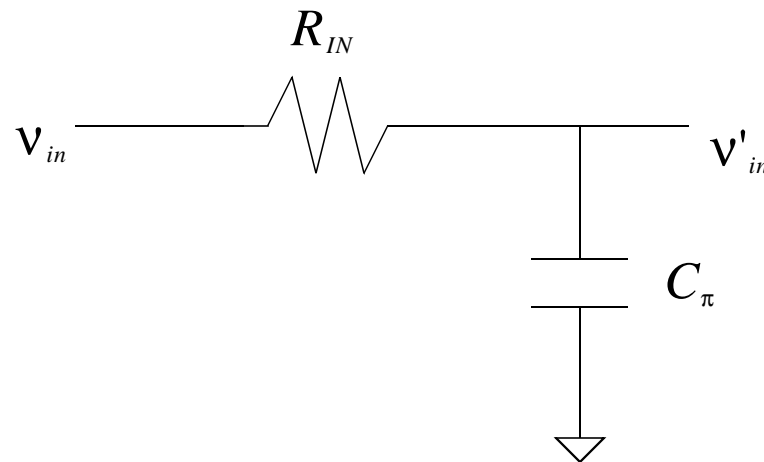

$$\frac{v'_{in}}{v_{in}} = \frac{\frac{1}{j\omega C_{\pi}}}{R_{IN} + \frac{1}{j\omega C_{\pi}}} = \frac{1}{1 + j\omega R_{IN} C_{\pi}}$$

$$\omega_p = \frac{1}{R_{IN} C_{\pi}}$$

Inverter (Cont.)

FR-30

Case 2 (Large C_D) :

$$R_{OUT}C_D \gg R_{IN}(1 + g_m R_{OUT})C_\mu, R_{IN}C_\pi$$

$$\omega_{p1} = \frac{1}{R_{OUT}C_D} \quad \omega_{p2} = \frac{1}{R_{IN}(C_\pi + C_\mu)}$$

Case 3 (Large C_μ) :

$$R_{IN}(1 + g_m R_{OUT})C_\mu \gg R_{OUT}C_D, R_{IN}C_\pi$$

$$\omega_{p1} = \frac{1}{R_{IN}(1 + g_m R_{OUT})C_\mu} \quad \omega_{p2} = \frac{1}{\frac{1}{g_m}(C_\pi + C_D)}$$

For case 2 and 3,

$$\omega_{ZERO} = \frac{g_m}{C_\mu}$$

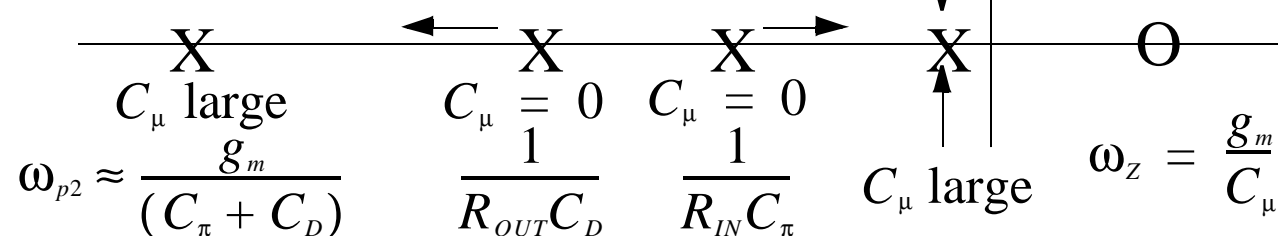

Source Follower

FR-31

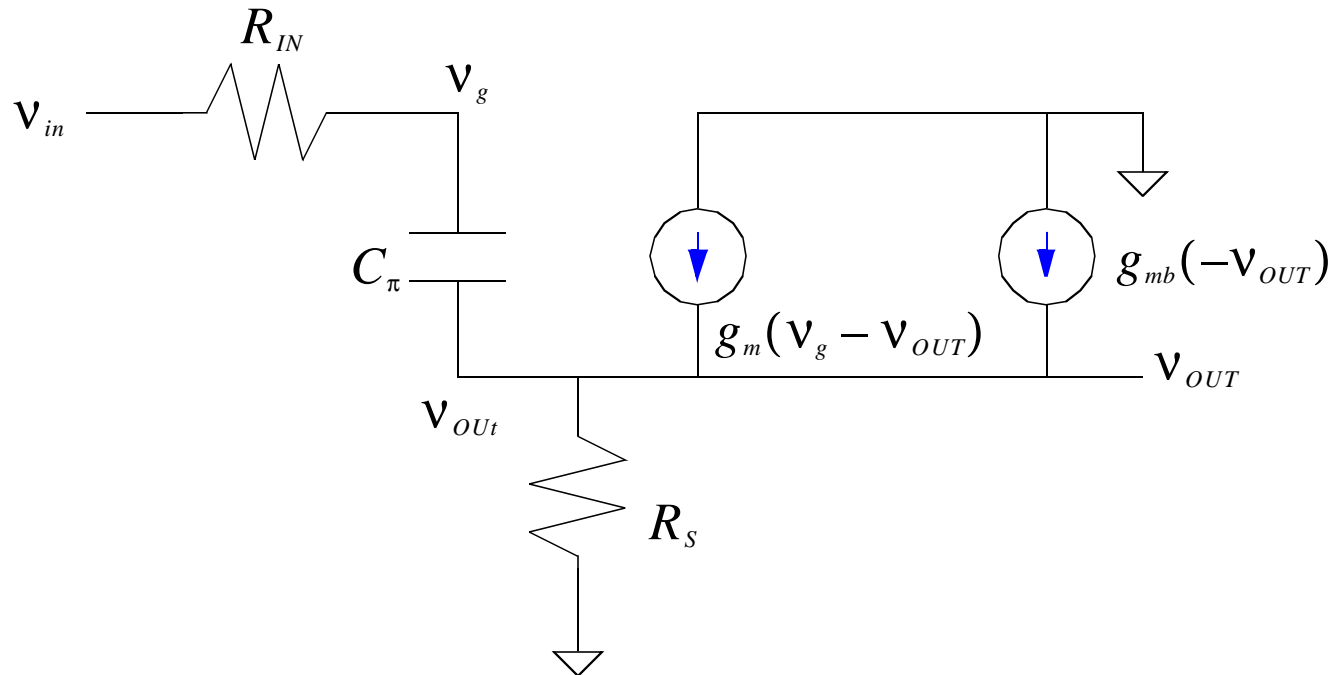

$$v_g = \left(\frac{1}{1 + j\omega R_{IN} C_\pi} \right) \cdot (v_{in} - v_{OUT}) + v_{OUT}$$

$$\frac{v_{OUT}}{R_S} = \frac{v_g - v_{OUT}}{\frac{1}{j\omega C_\pi}} + g_m \cdot v_g - (1 + \chi) \cdot g_m \cdot v_{OUT}$$

Source Follower (Cont.)

FR-32

$$v_{OUT} \cdot \left(\frac{1}{R_S} + (1 + \chi) \cdot g_m + j\omega C_\pi \right) = (j\omega C_\pi + g_m) \cdot v_g$$

$$\frac{v_{OUT}}{v_{in}} = \frac{g_m R_S}{1 + (1 + \chi) \cdot g_m R_S} \cdot \left[\frac{\left(1 + j\omega \frac{C_\pi}{g_m} \right)}{1 + j\omega R_{IN} \underbrace{\frac{C_\pi (1 + \chi \cdot g_m R_S)}{1 + (1 + \chi) g_m R_S}}_{1 - A}} \right]$$

$$\omega_Z = \frac{g_m}{C_\pi}$$

$$\omega_p = \frac{1}{R_{IN} C_\pi (1 - A)}$$

$$A_v = \frac{g_m R_S}{1 + (1 + \chi) g_m R_S}$$

$$A = \frac{g_m R_S}{1 + (1 + \chi) g_m R_S}$$

FR-33

Source Follower again with C_{SB}

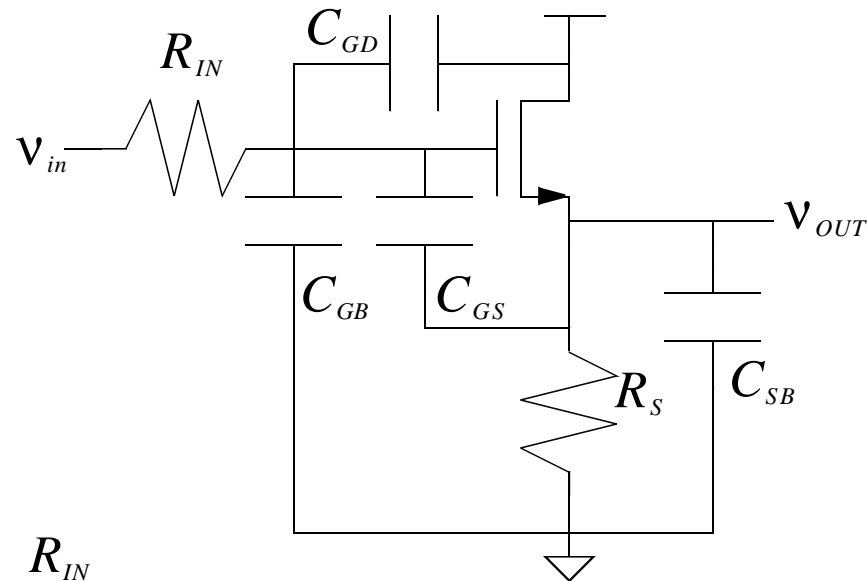

Small Signal :

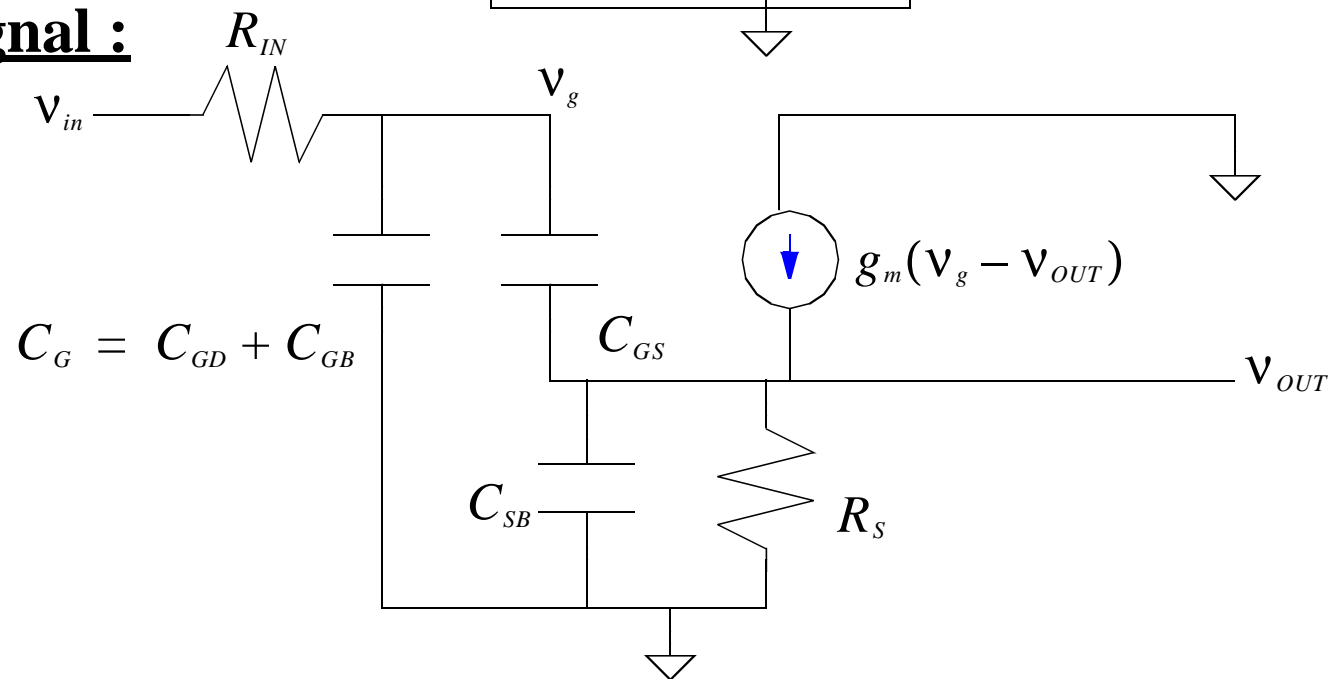

Source Follower (Cont.)

$$\frac{v_{in} - v_G}{R_{IN}} = v_G \cdot j\omega C_G + (v_G - v_{OUT}) \cdot j\omega C_{GS}$$

$$(v_G - v_{OUT}) \cdot j\omega C_{GS} - g_m(v_G - v_{OUT}) = \frac{v_{OUT}}{R_S} + v_{OUT} \cdot j\omega C_{SB}$$

$$\frac{v_{OUT}}{v_{in}} = \frac{\frac{g_m R_S}{1 + g_m R_S} \cdot \left[1 + j\omega \frac{C_{GS}}{g_m} \right]}{1 + j\omega \left[R_{IN} C_G + \frac{R_{IN} C_{GS}}{1 + g_m R_S} + \frac{R_S (C_{GS} + C_{SB})}{1 + g_m R_S} \right] - \omega^2 R_S R_{IN} \left[\frac{C_{GS} C_G + C_{SB} (C_G + C_{GS})}{1 + g_m R_S} \right]}$$

$$\begin{aligned} \text{let denominator} &= \left(1 + j\frac{\omega}{p_1} \right) \cdot \left(1 + j\frac{\omega}{p_2} \right) \\ &= 1 + j\omega \left(\frac{1}{p_1} + \frac{1}{p_2} \right) - \frac{\omega^2}{p_1 p_2} \end{aligned}$$

Source Follower (Cont.)

FR-35

for p_1 and p_2 widely separated, if we assume that p_1 is the dominant pole,

$$\frac{1}{p_1} \gg \frac{1}{p_2}$$

$$p_1 = \frac{1}{R_{IN}C_G + \frac{R_{IN}C_{GS}}{1 + g_m R_S} + \frac{R_S(C_{GS} + C_{SB})}{1 + g_m R_S}} = \frac{1}{R_{IN}C_G + \frac{R_{IN}C_{GS}}{1 + g_m R_S} + R_O(C_{GS} + C_{SB})}$$

where,

$$R_O = \frac{1}{g_m} \parallel R_S$$

thus,

$$p_2 = \frac{R_{IN}C_G + \frac{R_{IN}C_{GS}}{1 + g_m R_S} + R_O(C_{GS} + C_{SB})}{R_O R_{IN} [C_{GS}C_G + C_{SB}C_G + C_{SB}C_{GS}]}$$

Source Follower (Cont.)

FR-36

2 limiting cases,

Case 1 :

$$R_{IN} \left(C_G + \frac{C_{GS}}{1 + g_m R_S} \right) \gg R_O (C_{GS} + C_{SB})$$

$$\omega_{p1} = \frac{1}{R_{IN} \left(C_G + \frac{C_{GS}}{1 + g_m R_S} \right)}$$

$$\text{Miller cap} = C_{GS} \cdot (1 - A)$$

$$A = \frac{g_m R_S}{1 + g_m R_S}$$

$$1 - A = 1 - \frac{g_m R_S}{1 + g_m R_S} = \frac{1}{1 + g_m R_S}$$

Case 2 :

$$R_O (C_{GS} + C_{SB}) \gg R_{IN} \left(C_G + \frac{C_{GS}}{1 + g_m R_S} \right)$$

$$\omega_{p1} = \frac{1}{R_O (C_{GS} + C_{SB})}$$

FR-37

Common Gate

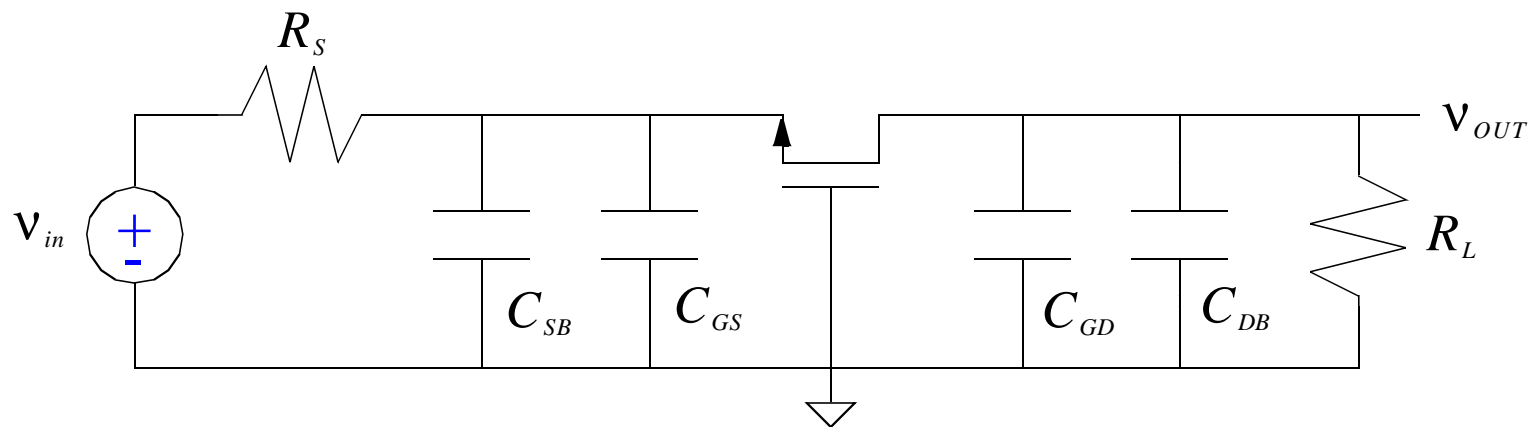

assume $r_o \rightarrow \infty$

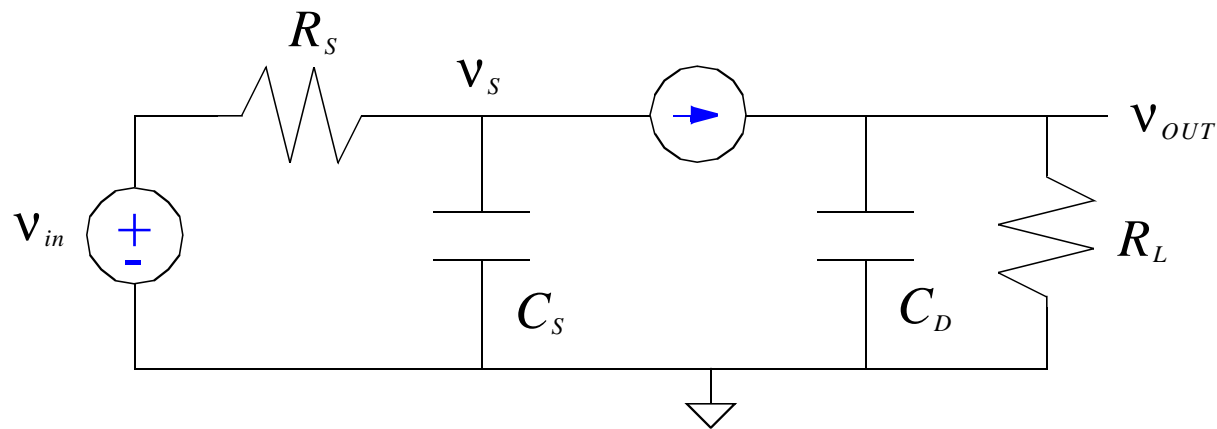

Common Gate (Cont.)

FR-38

$$\text{KCL@ } v_s \quad \frac{v_{in} - v_s}{R_s} = v_s \cdot j\omega C_s + g_m v_s$$

$$\text{KCL@ } v_{OUT} \quad g_m v_s = v_{OUT} \cdot j\omega C_D + \frac{v_{OUT}}{R_L}$$

$$\frac{v_{OUT}}{v_{in}} = \frac{\frac{g_m R_L}{1 + g_m R_s}}{(1 + j\omega R_L C_D) \cdot \left(1 + j\omega \frac{R_s C_s}{1 + g_m R_s}\right)}$$

no zeros, poles @

$$p_1 = \frac{1}{R_L C_D}$$

$$p_2 = \frac{1}{\frac{R_s}{1 + g_m R_s} C_s} = \frac{1}{\left(R_s \parallel \frac{1}{g_m}\right) C_s}$$

Common Gate (Cont.)

$$\begin{array}{l} @ \ v_{OUT} \rightarrow R_{eq} = R_L \\ \quad \quad \quad C_{eq} = C_D \end{array} \quad \Rightarrow \quad p_1 = \frac{1}{R_{eq} C_{eq}} = \frac{1}{R_L C_D}$$

$$\begin{array}{l} @ \ v_S \rightarrow R_{eq} = R_S \parallel \frac{1}{g_m} \\ \quad \quad \quad C_{eq} = C_S \end{array} \quad \Rightarrow \quad p_2 = \frac{1}{R_{eq} C_{eq}} = \frac{1}{\left(R_S \parallel \frac{1}{g_m}\right) C_S}$$

Since all caps go to ground, finding poles reduces to finding Req's and Ceq's at the nodes.

Cascode - reduces the Miller problem

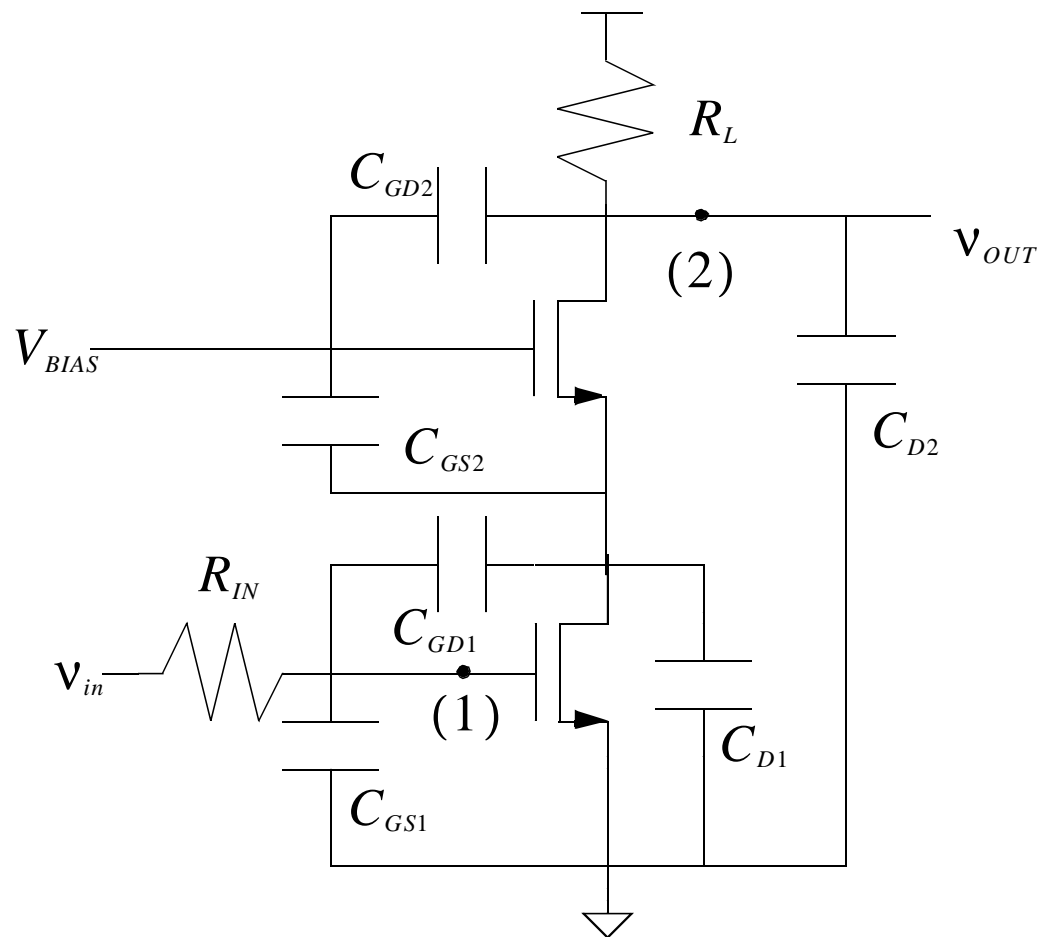

Cascode (Cont.)

FR-41

If we assume that R_s is very large, then,

At (1) :

$$R_{eq} = R_s$$

$$C_{eq} = C_{GS1} + C_{GD1} \cdot (1 - A)$$

$$A = -g_m \cdot \frac{1}{g_m} = -1$$

$$C_{eq} = C_{GS1} + 2 \cdot C_{GD1}$$

$$p_1 = \frac{1}{R_{eq} C_{eq}}$$

At (2) :

$$R_{eq} = R_L \parallel r_o \leftarrow \text{large}$$

$$C_{eq} = C_{GD2} + C_{D2}$$

$$p_2 = \frac{1}{R_{eq} C_{eq}}$$

No large Miller multiplication of a capacitance!

Zero Value Time Constant Analysis

FR-42

General case of dominant pole approximation. Use this technique for complex circuits where we can't identify node with large R_{eq} and C_{eq} .

Strategy :

- 1) Set all caps $C_j=0$ except for C_i
- 2) Find resistance seen by C_i
- 3) Calculate $R_i C_i$ for all caps
- 4)
$$\omega_{3dB} = \frac{1}{\sum R_i C_i}$$

ZVTC with Source Follower

FR-43

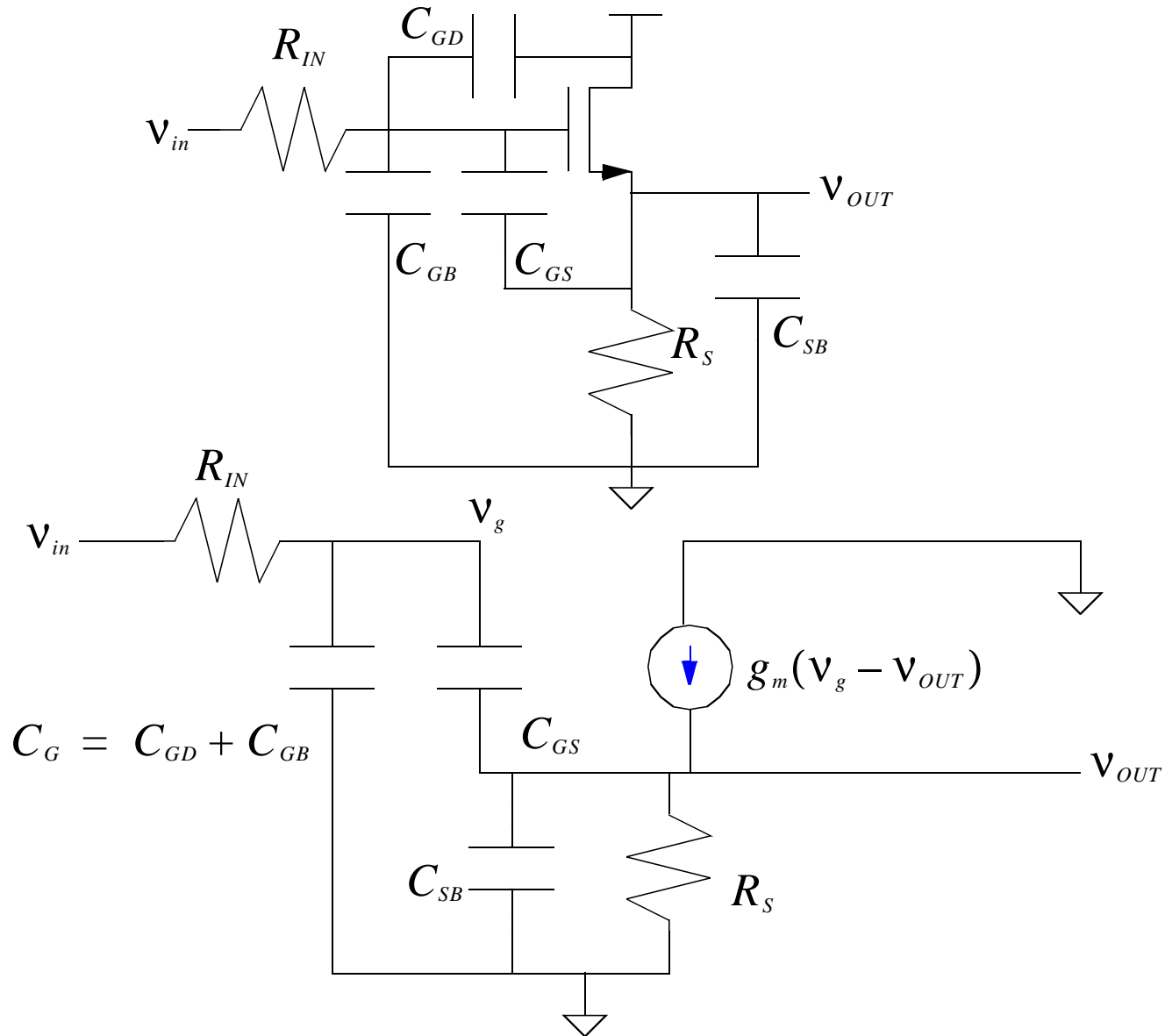

ZVTC with Source Follower

FR-44

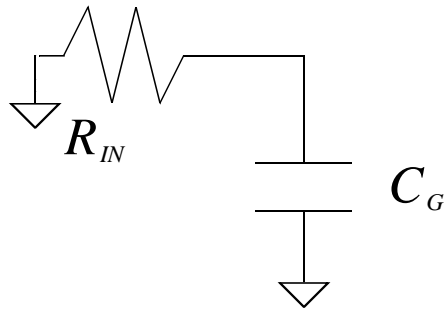
 $C_1 :$ 

$$R_1 = R_{IN}$$

$$C_1 = C_G$$

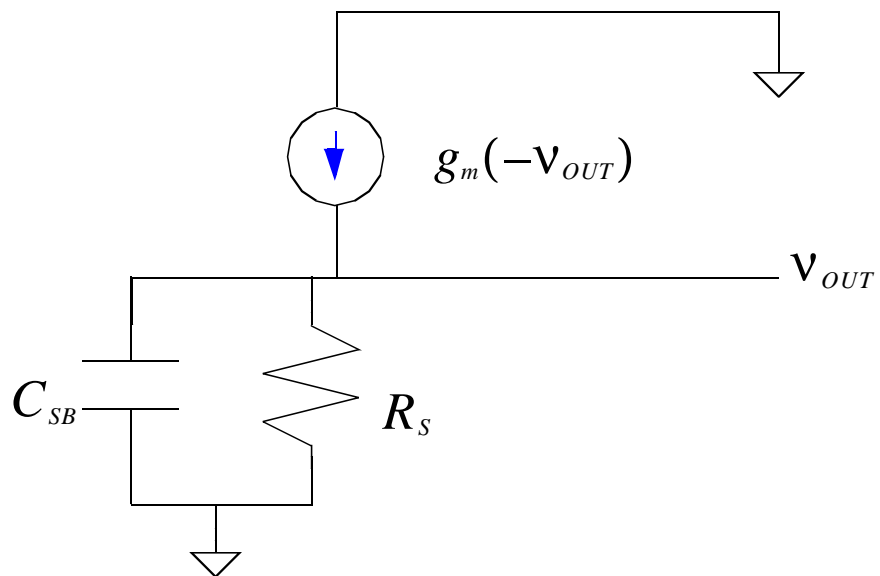
 $C_2 :$ 

$$R_2 = R_S \parallel \frac{1}{g_m}$$

$$C_2 = C_{SB}$$

ZVTC with Source Follower (Cont.)

FR-45

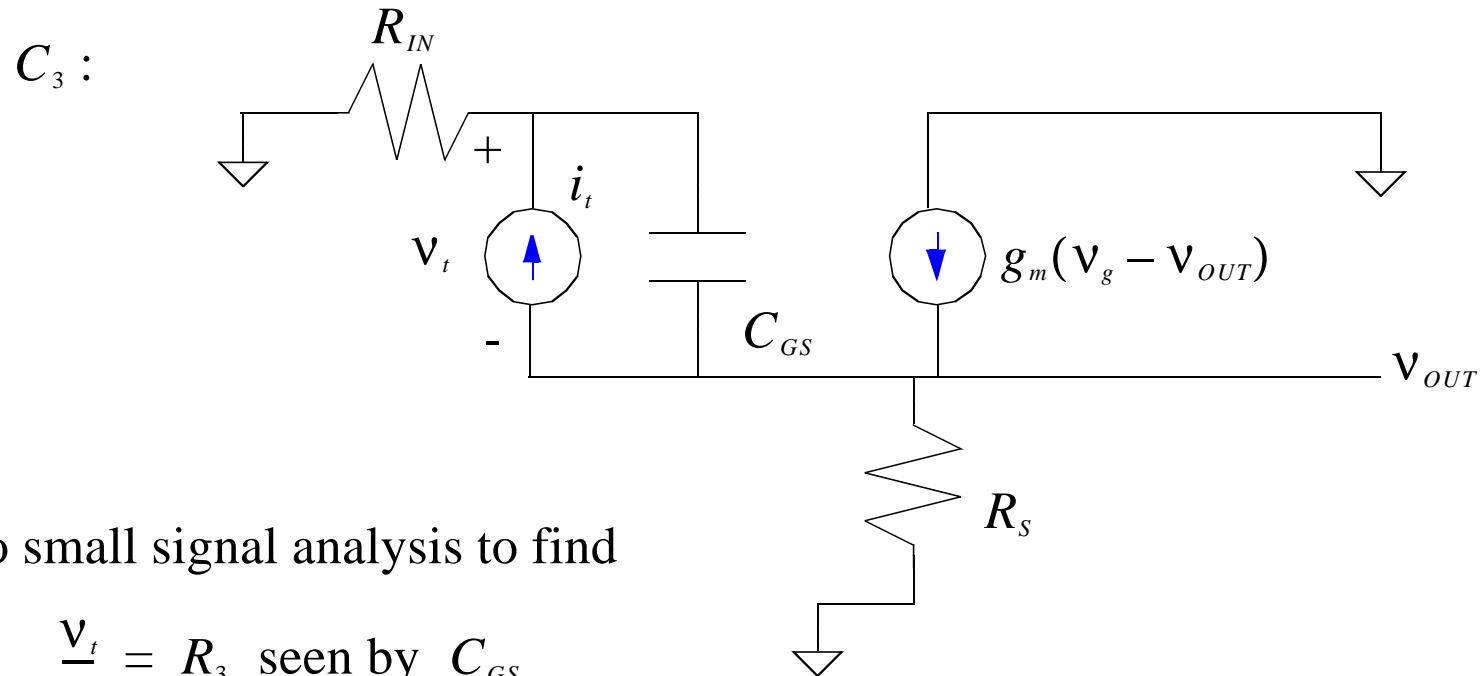

do small signal analysis to find

$$\frac{v_t}{i_t} = R_3 \text{ seen by } C_{GS}$$

$$R_3 = R_o + \frac{R_{IN}}{1 + g_m R_S} \text{ where } R_o = R_S \parallel \frac{1}{g_m} \quad C_3 = C_{GS}$$

hence,

$$\omega_{3dB} = \frac{1}{R_1 C_1 + R_2 C_2 + R_3 C_3} = \frac{1}{R_{IN} C_G + R_o C_{SB} + \left(R_o + \frac{R_{IN}}{1 + g_m R_S} \right) C_{GS}}$$