

Series-Shunt

FB-58

Take OUTPUT from source of Series Triple

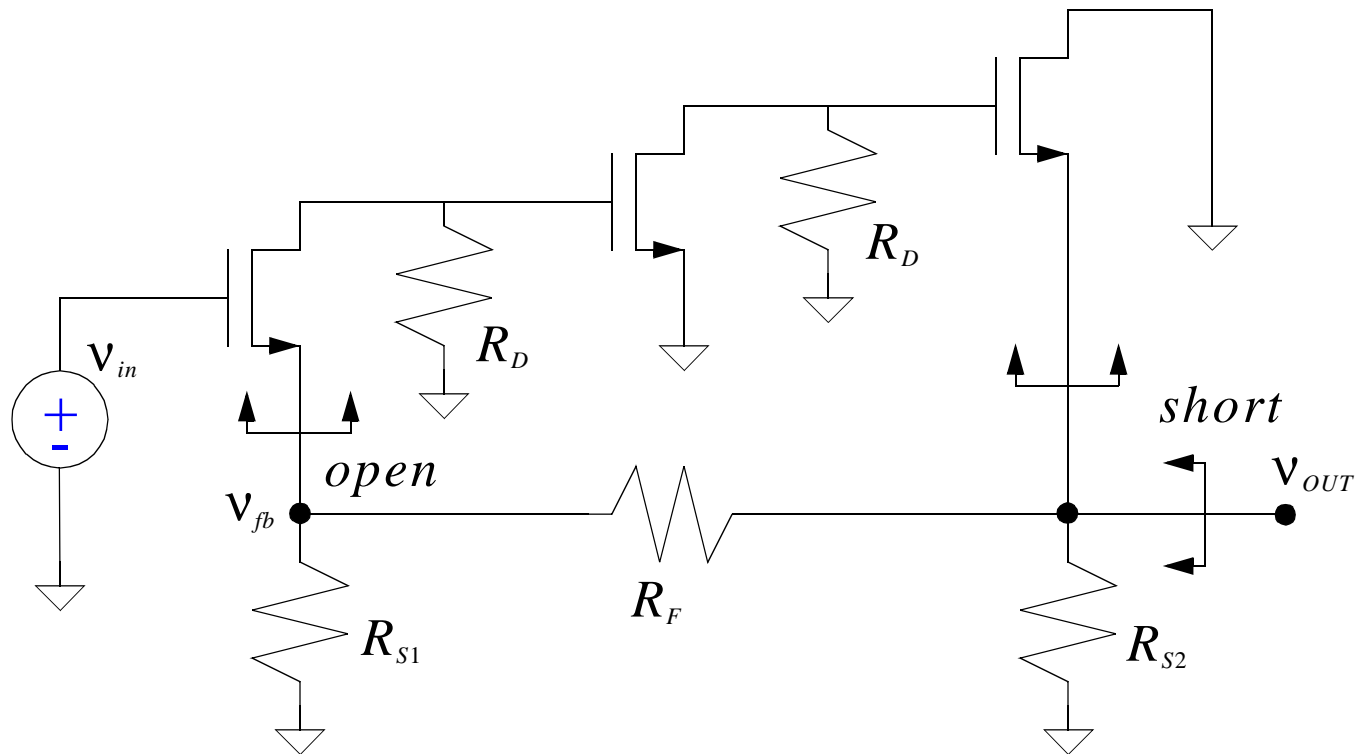

Series-Shunt (Cont.)

FB-59

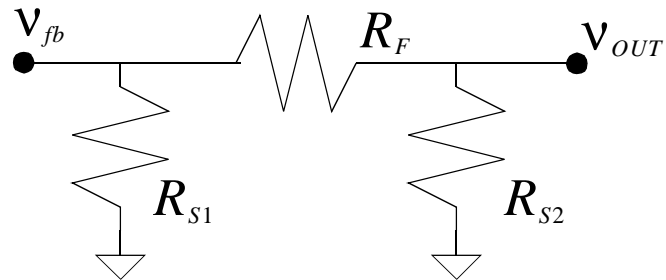

$$f_v = \frac{V_{fb}}{V_{OUT}} = \frac{R_{S1}}{R_F + R_{S1}}$$

$$R_{OUT} = \frac{r_{OUT}'}{1 + a_v' f_v}$$

Series-Shunt (Cont.)

FB-60

Basic amplifier with loading :

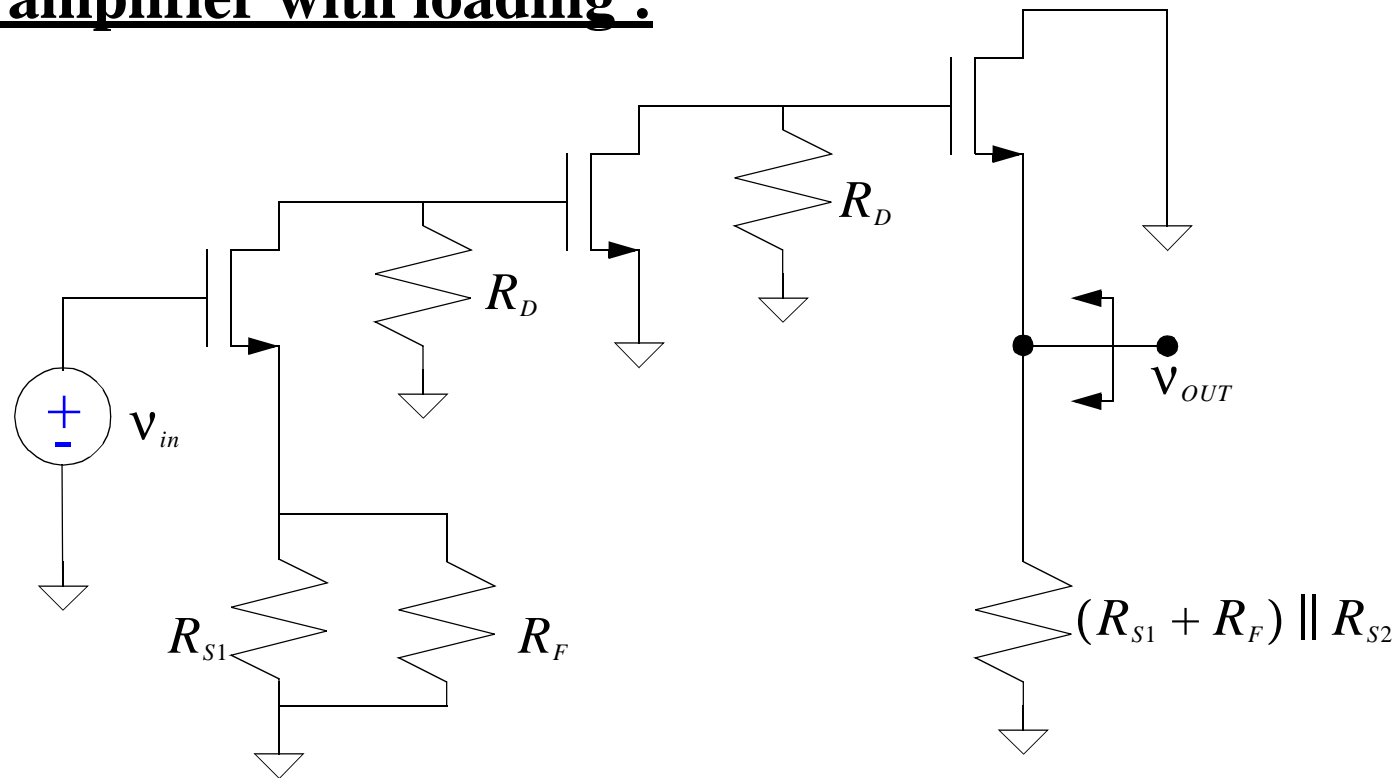

$$r_{OUT}' = \frac{1}{g_m} \parallel (R_{S1} + R_F) \parallel R_{S2}$$

$$a_v' = \frac{g_m^3 \cdot R_D^2}{[1 + (1 + \chi) \cdot g_m \cdot (R_S \parallel R_F)] \cdot [1 + (1 + \chi) \cdot g_m \cdot (R_{S1} + R_F) \parallel R_{S2}]}$$

Series-Shunt (Cont.)

FB-61

Another method is the “Break the loop” strategy for multi-stage circuits.

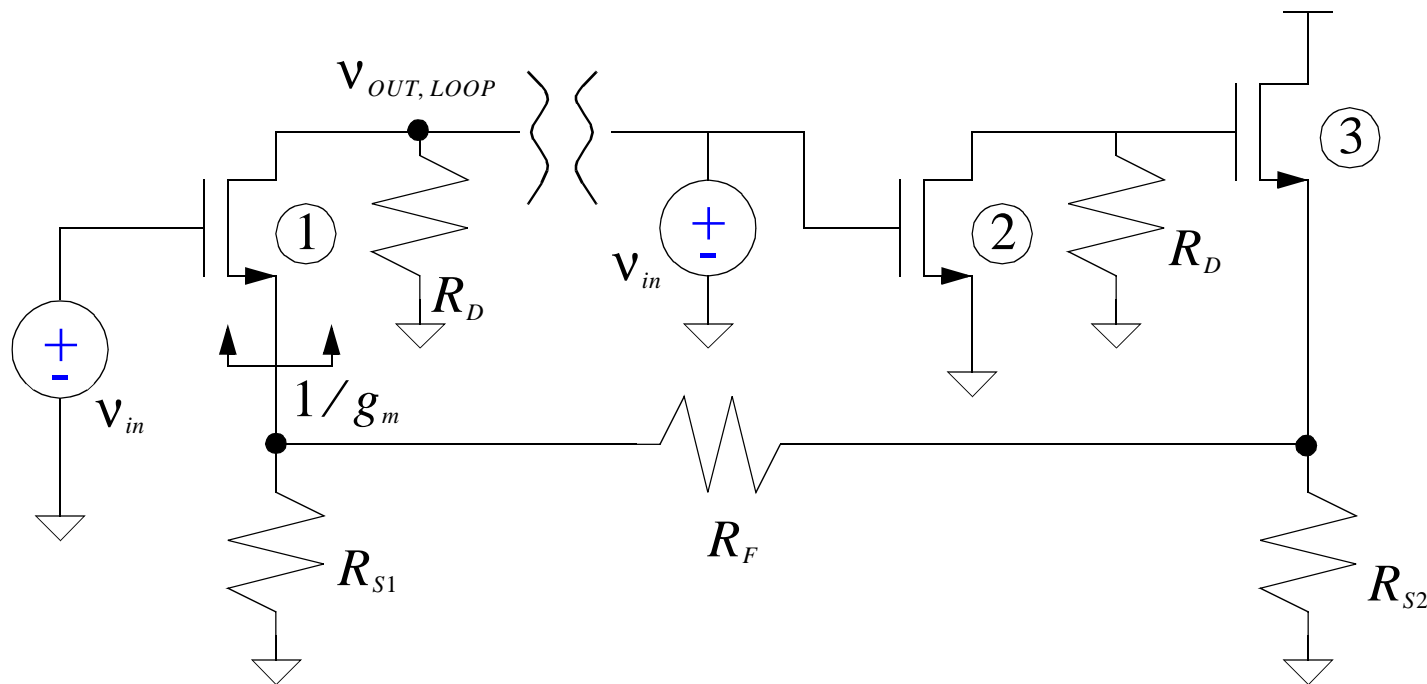

$$T' = \frac{v_{OUT, LOOP}}{v_{in}}$$

Series-Shunt (Cont.)

FB-62

$$T' = \frac{V_{OUT, LOOP}}{V_{in}}$$

$$r_o \gg R_D$$

$$T' = (g_{m2} \cdot R_D) \cdot \left(\frac{g_m \cdot \left(R_{S2} \parallel \left(R_F + \frac{1}{g_m} \parallel R_{S2} \right) \right)}{1 + g_m \cdot \left(R_{S2} \parallel \left(R_F + \frac{1}{g_m} \parallel R_{S2} \right) \right)} \right) \cdot \underbrace{\frac{R_{S2} \parallel \frac{1}{g_m}}{R_F + R_{S2} \parallel \frac{1}{g_m}}}_{\text{Through Feedback Network}} \cdot g_{m2} \cdot R_D$$

FB-63

Series-Series / Triple

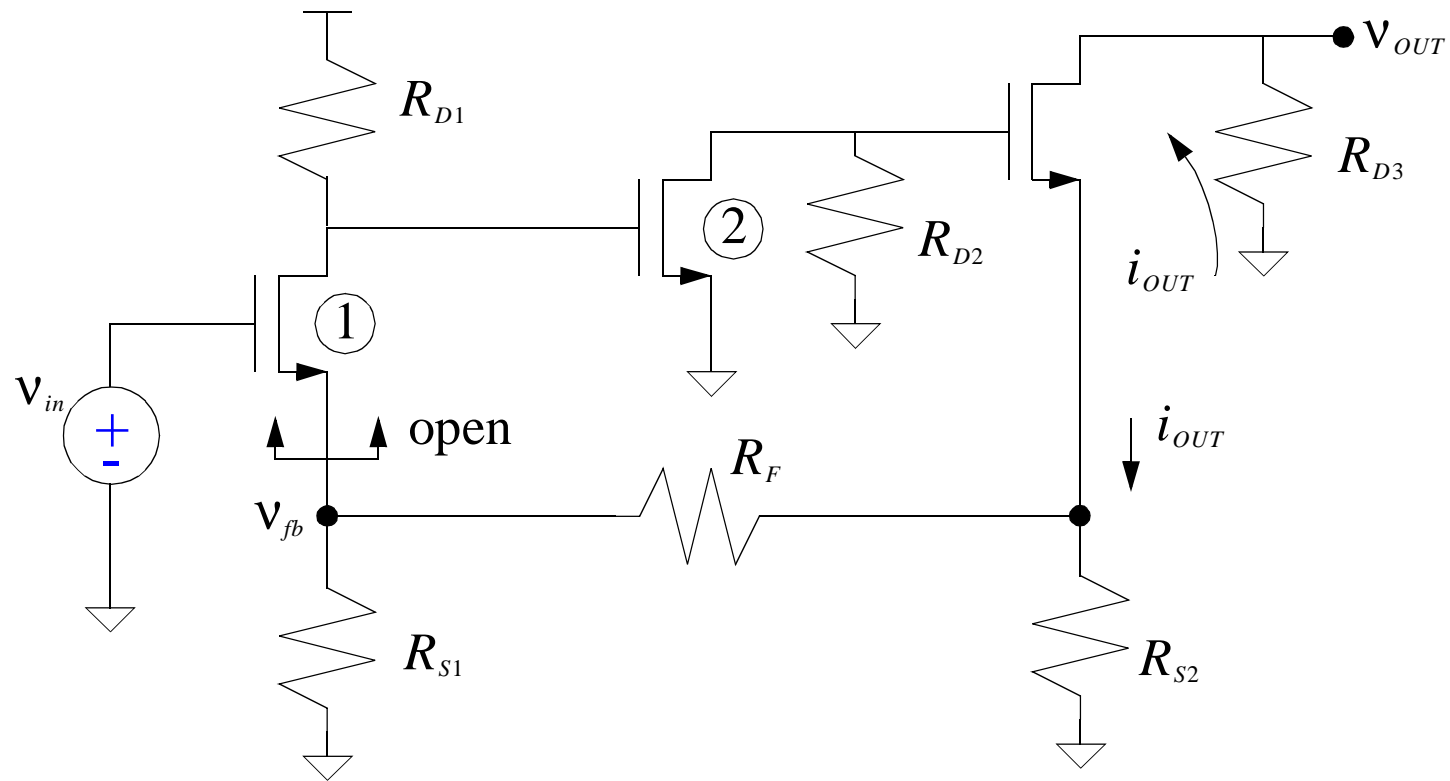

Series-Series / Triple (Cont.)

FB-64

Sensing i_{OUT} in source, though i_{OUT} is in drain.

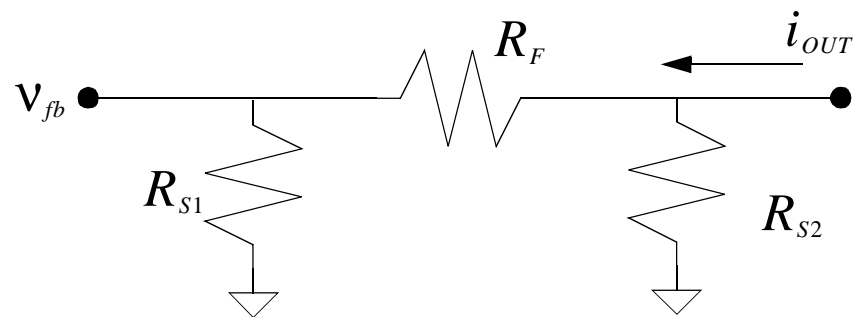

$$\frac{v_{fb}}{i_{OUT}} = R_{S1} \cdot \left(\frac{R_{S2}}{R_{S2} + R_F + R_{S1}} \right) = f_R$$

Series-Series / Triple (Cont.)

FB-65

$$A_G = \frac{i_{OUT}}{V_{in}} = \frac{1}{f_R} \cdot \left(\frac{T'}{1 + T'} \right)$$

$$T' = a_G \cdot f_R$$

$$A_G = \frac{1}{f_R} = \left(\frac{R_{S1} + R_{S2} + R_F}{R_{S1} \cdot R_{S2}} \right)$$

$$V_{OUT} = -i_{OUT} \cdot R_{D3}$$

$$\frac{V_{OUT}}{V_{in}} = \frac{V_{OUT}}{i_{OUT}} \cdot \frac{i_{OUT}}{V_{in}}$$

$$\frac{V_{OUT}}{V_{in}} = -A_G \cdot R_{D3} = -\frac{(R_{S1} + R_{S2} + R_F) \cdot R_{D3}}{R_{S1} \cdot R_{S2}}$$

Series-Series / Triple (Cont.)

FB-66

Basic amplifier with loading :

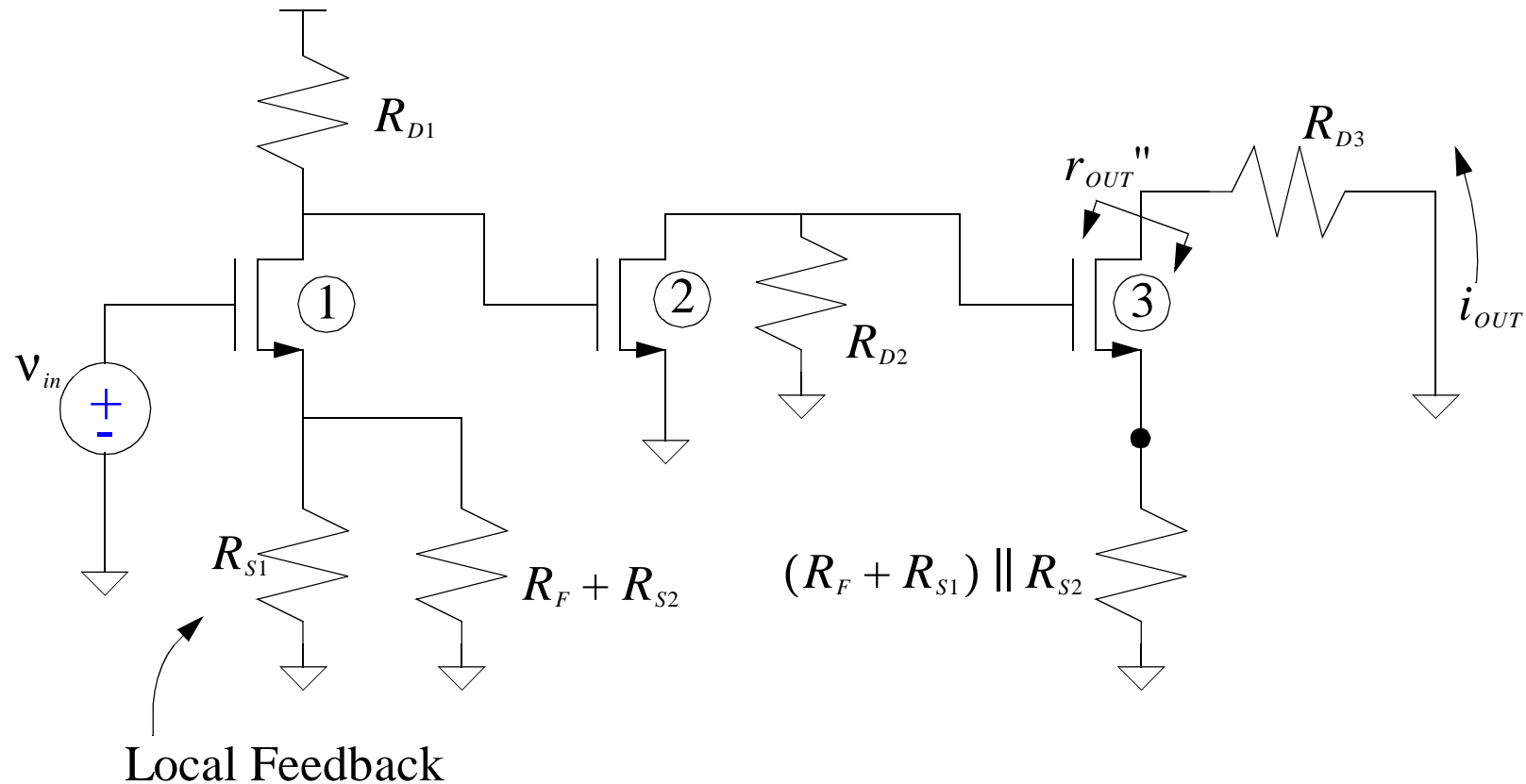

$$\text{If } \rightarrow R_{D1} = R_{D2} = R_{D3} = R_D \quad R_{S1} = R_{S2} = R_S$$

$$\text{and } \rightarrow R_D \ll r_o \cdot [1 + g_m \cdot (1 + \chi) \cdot R_S] \quad \text{then,}$$

Series-Series / Triple (Cont.)

$$a_G' = \frac{i_{OUT}}{V_{in}} = (\text{Current Division at Output}) \cdot (\text{Trans 1}) \cdot (\text{Trans 2}) \cdot (\text{Trans 3})$$

$$\text{Current Division at Output} = \frac{r_{OUT}''}{r_{OUT}'' + R_{D3}}$$

$$\text{Trans 1} = \frac{g_m \cdot R_{D1}}{[1 + (1 + \chi) \cdot g_m \cdot R_S \parallel (R_F + R_{S2})]}$$

$$\text{Trans 2} = g_m \cdot R_{D2}$$

$$\text{Trans 3} = \frac{g_m}{1 + (1 + \chi) \cdot g_m \cdot R_S \parallel R_F + R_{S2}}$$

$$a_G' = \frac{g_m^3 \cdot R_D^2 \cdot \left(\frac{r_{OUT}''}{r_{OUT}'' + R_D} \right)}{[1 + (1 + \chi) \cdot g_m \cdot (R_S \parallel (R_F + R_S))]^2}$$

Series-Series / Triple (Cont.)

FB-68

$$r_{OUT}' = R_{D3} + \underbrace{r_{o3} \cdot [1 + (1 + \chi) \cdot g_m \cdot (R_S \parallel (R_F + R_S))]}_{r_{OUT}''}$$

$$R_{OUT}' = r_{OUT}' \cdot (1 + a_G' \cdot f_R)$$

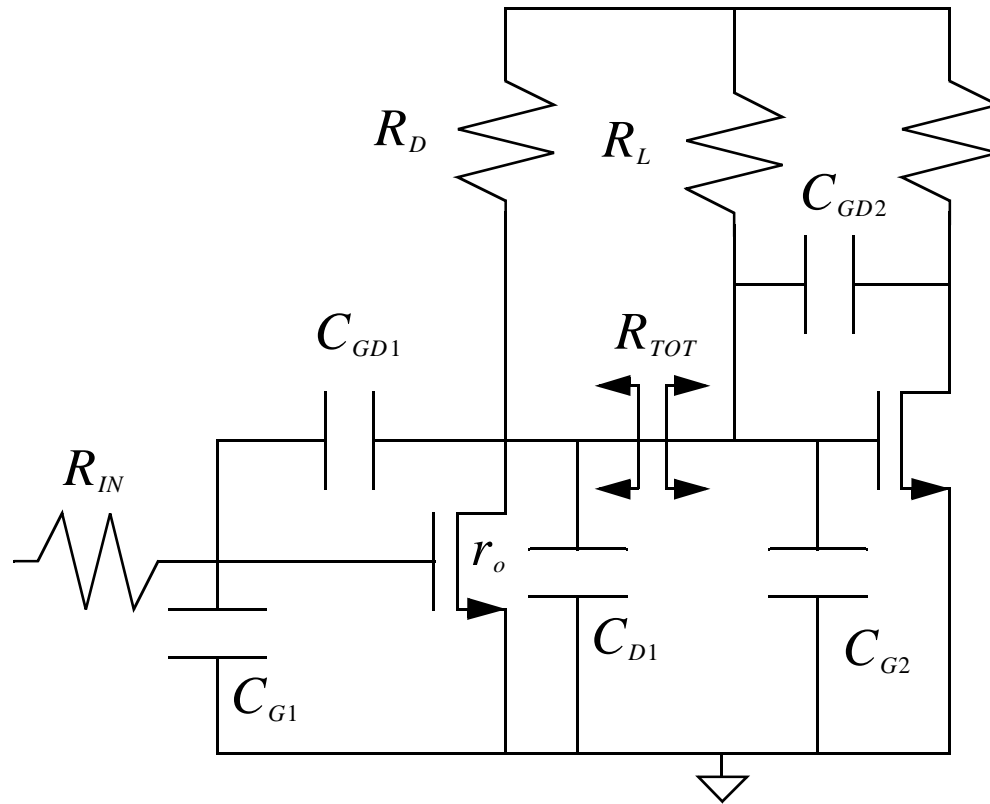

For $C_{GD1} = 0$,

$$R_{TOT} = r_o \parallel R_D \parallel R_L$$

$$C_{TOT} = C_{D1} + C_{G2} + C_{GD2}(1 + A)$$

$$p_1 = \frac{1}{C_{TOT}R_{TOT}}$$

For C_{GD1} a short,

$$R_{TOT} = r_o \parallel R_D \parallel R_L \parallel \frac{1}{g_m}$$

C_{TOT} remains the same as above

For $R_{IN} = 0$,

$$C_{TOT} = C_{D1} + C_{G2} + C_{GD2}(1 + A) + C_{GD1}$$