



## ***Ultra-Low Energy Wireless Sensor and Monitor Networks***

Jan M. Rabaey

<http://www.eecs.berkeley.edu/~jan>

In cooperation with Profs B. Brodersen, A. Sangiovanni-Vincentelli,  
K. Ramchandran, P. Wright, and the PicoRadio group.



### ***PicoRadio Charter***

Develop meso-scale low-cost radio's for ubiquitous wireless data acquisition that **minimize power/energy dissipation**

- Minimize energy ( $< 5$  nJ/(correct) bit) for energy-limited source
- Minimize power ( $< 100$   $\mu$ W) for power-limited source (enabling energy scavenging)
- Target date 2004

By using the following strategies

- self-configuring networks
- fluid trade-off between communication and computation
- aggressive low-energy architectures and circuits



# The Applications and Specs

The Obvious Choice - The Smart Home and Network Appliances

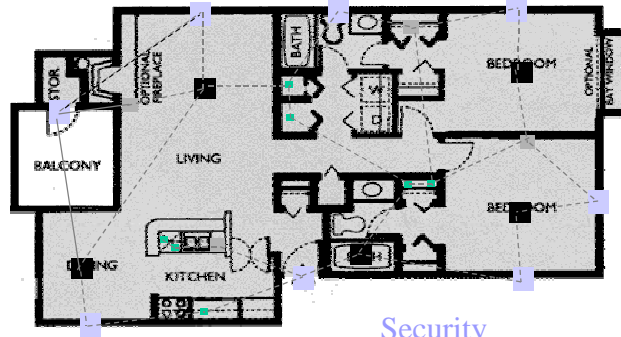

Dense network of sensor and monitor nodes

- Security
- Environment monitoring and control
- Object tagging
- Identification

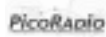

# Wireless in the Home

Home-networked households in the United States, in thousands

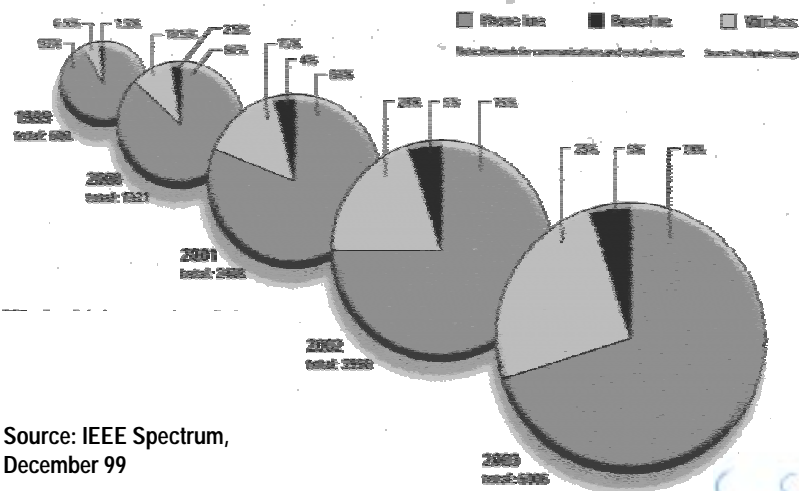

Source: IEEE Spectrum, December 99



# Industrial Building Environment Management



- Task/ambient conditioning systems allow thermal condition in small, localized zones (e.g. work-stations) to be individually controlled by building occupants
- Requires dense network of sensor/monitor nodes
- Wireless infrastructure provides flexibility in composition and topology
- Joint research proposal CBE/BSAC/BWRC

PicoRadio



# The Interactive Museum

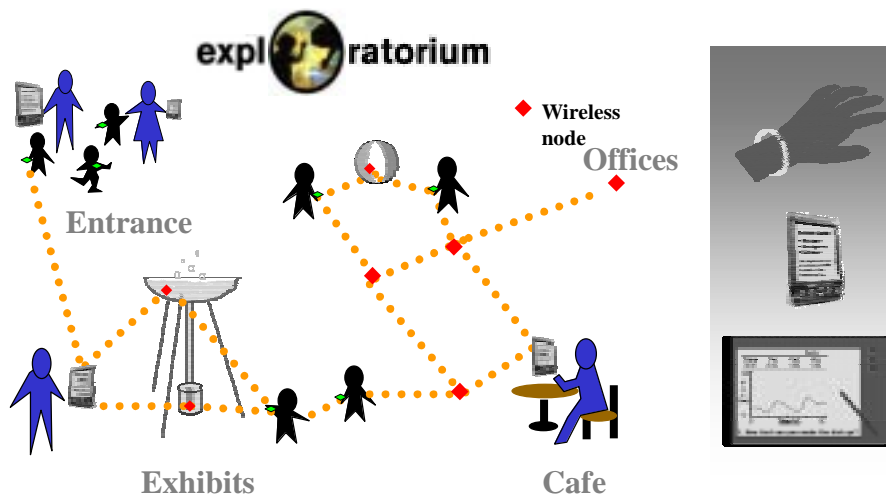

PicoRadio

Other applications: toys, manufacturing, ...



## System Requirements and Constraints

### (from Exploratorium scenario)

- Large numbers of nodes — between 0.05 and 1 nodes/m<sup>2</sup>
- Cheap (<0.5\$) and small (< 1 cm<sup>3</sup>)
- Limited operation range of network — maximum 50-100 m
- Low data rates per node — 1-10 bits/sec average
  - up to 10 kbit/sec in rare local connections to potentially support non-latency critical voice channel
- **Crucial Design Parameter:**  
**Spatial capacity (or density) — 100-200 bits/sec/m<sup>2</sup>**

PicoRadio



## How to get there?

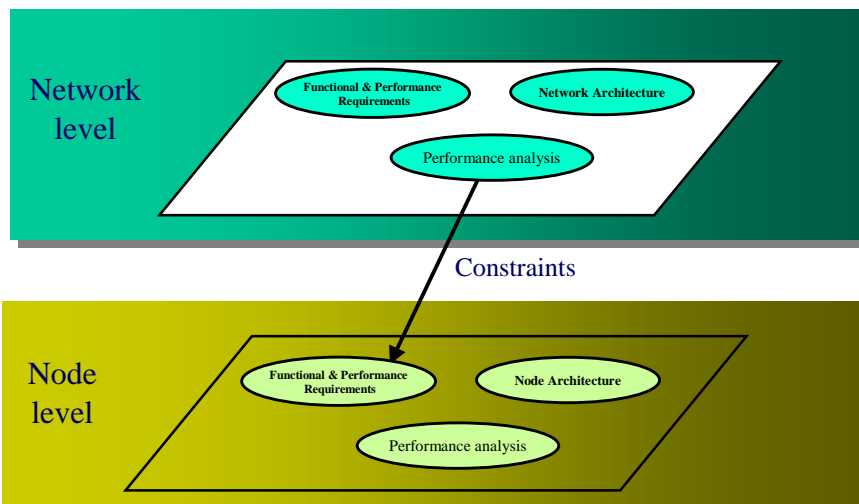

PicoRadio

**Think Energy!**



## *Opportunities*

- **Exploit the application properties**
  - Sensor data is correlated in time and space
  - Sensing without precise localization seldom makes sense
  - Sensor networks rarely do need precise addressing
  - Duty cycle of sensor nodes is very small
- **And use node architectures that excel in the “common case”**
  - Stream-based data flow processing for baseband
  - Concurrent Finite State Machines for protocol stack

PicoRadio



## *Some interesting numbers*

- **Energy cost of digital computation**
  - 1999 (0.25 $\mu$ m): 1pJ/op (custom) ... 1nJ/op ( $\mu$ proc)
  - 2004 (0.1 $\mu$ m): 0.1pJ/op (custom) ... 100pJ/op ( $\mu$ proc)
    - Factor 1.6 per year; Factor 10 over 5 years
    - Assuming reconfigurable implementation: 1 pJ/op
- **Energy cost of communication**
  - 1999 Bluetooth (2.4 GHz band, 10m distance)
    - 1 nJ/bit transmission energy (thermal limit 30 pJ/bit)
    - Overall energy: 170 nJ/bit reception / 150 nJ/bit transmission (!)
    - Standby power: 300  $\mu$ W
  - 2004 Radio (10 m)
    - Only minor reduction in transmission energy
    - Reduce transceiver energy with at least a factor 10-50
- **Trade-off**
  - @10m: 5000 operations / transmitted bit
  - @ 1m: 0.5 operations / transmitted bit

PicoRadio



## Power & energy dissipation in ad-hoc wireless networks

$$P_{link} = (\alpha + \beta \times dist^\gamma) \times \frac{bits}{sec} + P_{standby}$$

$$= \varepsilon (\alpha + \beta \times dist^\gamma) \times \frac{actual\_bits}{sec} + P_{standby}$$

$$E_{actual\_bit} = \varepsilon \times (\alpha + \beta \times dist^\gamma) + \frac{P_{standby}}{actual\_bits/sec}$$

$\alpha$ : computation energy for transceiving a single bit  
 $\beta$ : transmission cost factor for a single bit  
 $\gamma$ : path-loss exponent (2..4)  
 $\varepsilon$ : overhead (in extra bits needed for transmission of a single bit)

- $P_{standby}$ : standby power (eg., due to need to keep receiver on)

\* These equations assume perfect power control

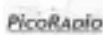

## Saving Power at the Application Layer

$$P_{link} = (\alpha + \beta \times dist^\gamma) \times \frac{bits}{sec} + P_{standby}$$

$$= \varepsilon (\alpha + \beta \times dist^\gamma) \times \frac{actual\_bits}{sec} + P_{standby}$$

$\alpha$ : computation energy for transceiving a single bit  
 $\beta$ : transmission cost factor for a single bit  
 $\gamma$ : path-loss exponent (2..4)  
 $\varepsilon$ : overhead (in extra bits needed for transmission of a single bit)

- $P_{standby}$ : standby power (eg., due to need to keep receiver on)

- **actual\_bits/sec: source coding**

Opportunity: sensor data is correlated in time and space

Trading off communication for computation



## Distributed Source Coding (Ramchandran)

- **Sensor networks present major spatial data correlation, but exploitation requires major intra-node communication**

### Good theoretical question:

How much performance loss if such communication unavailable?

- **Answer: *no performance loss!* (under certain conditions) based on non-constructive information-theoretic argument (Slepian-Wolf).**

### Engineering question:

How do we develop a practical and constructive framework to optimize global network usage?

## Distributed Source Coding using Spatial Correlation

- “Source Code”: Designed to get the desired distortion performance.
- **Joint quantization and estimation:**

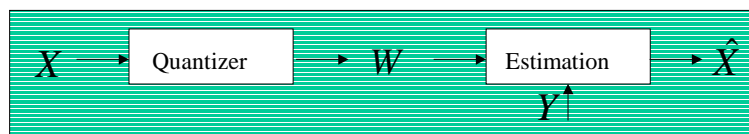

### Quantizer:

- Quantize  $X$  to a finite set of codewords ( $W$ ).  
(Mapping from  $X$  to  $W$ )
- The codewords in the set  $W \Rightarrow$  “Source Codes”

### Estimation:

- Estimate  $X$  from the index of  $W$  and the side information  $Y$ .  
(Mapping from  $W$  and  $Y$  to the reconstruction space  $\hat{X}$ .)

## Saving Power at the Network Layer

$$P_{link} = (\alpha + \beta \times dist^\gamma) \times \frac{bits}{sec} + P_{standby}$$

$$= \epsilon (\alpha + \beta \times dist^\gamma) \times \frac{actual\_bits}{sec} + P_{standby}$$

$\alpha$ : computation energy for transmission of a single bit  
 $\beta$ : transmission cost factor for a single bit  
 $\gamma$ : path-loss exponent (2..4)  
 $\epsilon$ : overhead (in extra bits needed for transmission of a single bit)  
 $P_{standby}$ : standby power (eg., due to need to keep receiver on)

- **dist**: network partitioning using multi-hop
  - **$\epsilon$** : cost of network discovery and maintenance
- Opportunities:
- exploit application (i.e. sensing) properties
  - merge with localization

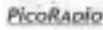

## Communicating over Long Distances

### Multi-hop Networks

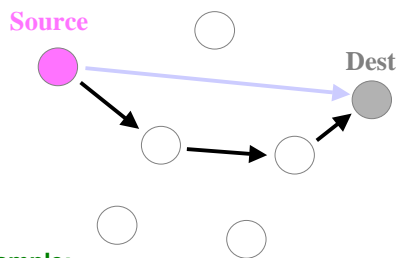

**Example:**

- 1 hop over 50 m  
1.25 nJ/bit
- 5 hops of 10 m each  
 $5 \times 2 \text{ pJ/bit} = 10 \text{ pJ/bit}$
- **Multi-hop reduces transmission energy by 125!**  
**(assuming path loss exponent of 4)**

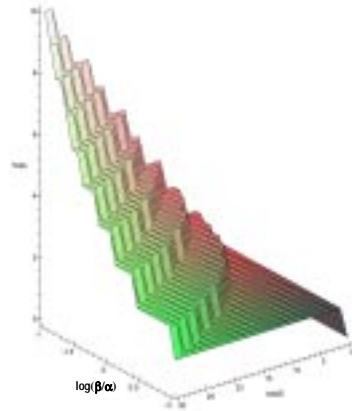

Optimal number of hops needed for free space path loss.

**But ... network discovery and maintenance overhead**

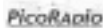

## *Proactive Routing*

- **Example: DSDV (Destination-Sequenced Distance Vector)**
  - Nodes continuously evaluate routes
  - Routes are (almost) always optimal
  - Efficient if many routes are popular
  - Two main type of update packets
    - Periodic Broadcast - scheduled update
      - Periodicity depends on how accurate a picture is needed about the network topology. The rate has to be faster than the rate at which the network is changing.
    - Triggered Broadcast - scheduled as needed.

## *Reactive Routing*

- **Examples: AODV (Ad-hoc On-Demand Distance Vector), DSR (Dynamic Source Routing)**
  - Nodes evaluate routes only on a “as-needed” basis.
  - Efficient if routes are used infrequently. Routes can become suboptimal over time.
    - New routes are acquired only if the old one expired or broke!
  - Two main types of routing packets
    - Request/Discovery Packet
      - Uses controlled flooding
    - Reply Packet
      - Unicasted back
  - Alternative versions directed towards sensor networks
    - Directed diffusion (Estrin) uses data-classes for addressing
    - Swarm intelligence (Sc. American March 00) uses reinforcement and evaporation

## Comparing the approaches from an energy perspective

- Energy =  $E_b \cdot \text{Packet Size}$
- Reactive Routing good for rarely used routes
- Proactive Routing good for frequently used routes
- Need solution that is more adequate for problem at hand: **class-based and location-based addressing.**

Routing Overhead (bytes)

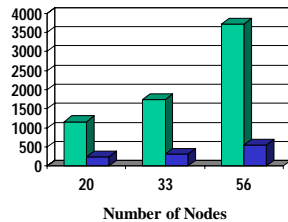

(discovering *one* route)

Routing Overhead (bytes) Normalized

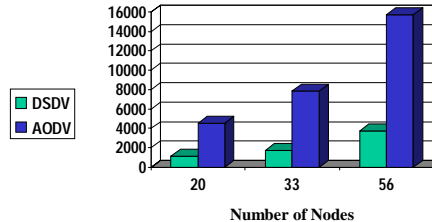

(discovering *n* routes)

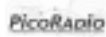

## Joined Networking-Positioning

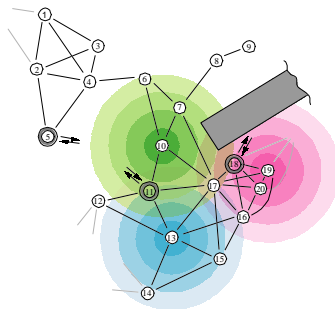

- Ubiquitous radio networks offer reasonable localization with minimal overhead
- Use network state to prune and filter updates
- Use positioning information to direct and dampen data traffic (**geographic routing - Jain**)

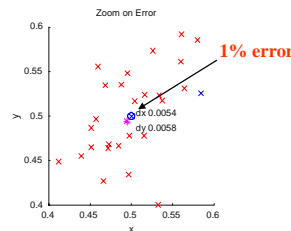
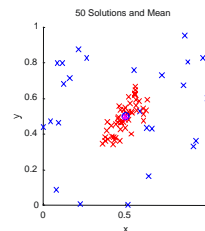
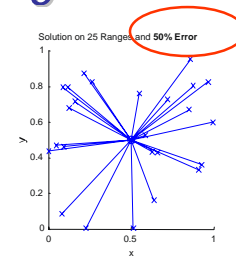
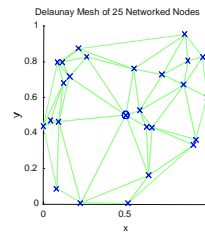

## Saving Power at the Media Access Layer (!)

$$P_{link} = (\alpha + \beta \times dist^\gamma) \times \frac{bits}{sec} + P_{standby}$$

$$= \epsilon (\alpha + \beta \times dist^\gamma) \times \frac{actual\_bits}{sec} + P_{standby}$$

$\alpha$ : computation energy for transceiving a single bit

$\beta$ : transmission cost factor for a single bit

$\gamma$ : path-loss exponent (2..4)

$\epsilon$ : overhead (in extra bits needed for transmission of a single bit)

- $P_{standby}$ : standby power (eg., due to need to keep receiver on)

- $P_{standby}$ : Power-management of inactive nodes

- $\epsilon$ : Cost of collisions and retransmissions (interference)

Opportunities: distribution of communication in time and frequency

- rendez-vous scheduling in local neighborhood
- usage of multiple virtual channels reduces interference



## Mostly-Sleepy MAC Layer Protocols

- **Computational** energy for receiving a bit is larger than the **computational** energy to transmit a bit (receiver has to discriminate and synchronize)
- **Most MAC protocols assume that the receiver is always on and listening!**
- **Activity in sensor networks is low and random**
- **Careful scheduling of activity pays off big time, but ... has to be performed in distributed fashion**
- **Options:**
  - Reactive MAC protocol, assumes that radio can be woken up - tough
  - Simulated reactive – each nodes occasionally wakes up and announces its presence - inefficient
  - Proactive or scheduled wake-up – challenge in ad-hoc networks, has to be addressed in distributed fashion

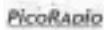

# Energy-Efficient Media Access

Example: Collision-sense multiple access (CSMA) with overlaid locally-synchronized TDMA framing (rendez-vous)

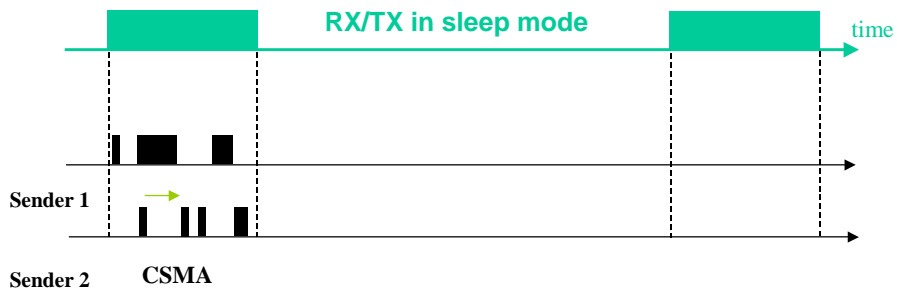

Adding multi-channel diversity (CDMA or FDMA) reduces collisions and retransmissions (channels allocated in distributed fashion)

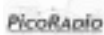

# Saving Power at the Physical Layer

$$P_{link} = (\alpha + \beta \times dist^\gamma) \times \frac{bits}{sec} + P_{standby}$$

$$= \left( \epsilon + \beta \times dist^\gamma \right) \times \frac{actual\_bits}{sec} + P_{standby}$$

- $\alpha$ : computation energy for transceiving a single bit
- $\beta$ : transmission cost factor for a single bit
- $\gamma$ : path-loss exponent (2..4)
- $\epsilon$ : overhead (in extra bits needed for transmission of a single bit)
- $P_{standby}$ : standby power (eg., due to need to keep receiver on)

- $\alpha$ : Choice of data rate, modulation, physical channel access
  - $\epsilon$ : Cost of framing, channel coding, synchronization, CRC
- Opportunities: radio's with fast acquisition (and probably less perfect channel)

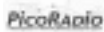

## PicoRadio Implementation Issues

- **Dynamic nature of PicoRadio networks requires adaptive, flexible solution**
- **Traditional programmable platforms cannot meet the stringent low-power requirements**
  - 3 orders of magnitude in energy efficiency between custom and programmable solutions
- **Configurable (parameterizable) architectures combine energy efficiency with limited flexibility**
- **System-on-a-chip approach enables integration of heterogeneous and mixed mode modules on same die**
- **Predicted improvements: factor 10 each year!**

PicoRadio



## The Mostly Digital Radio

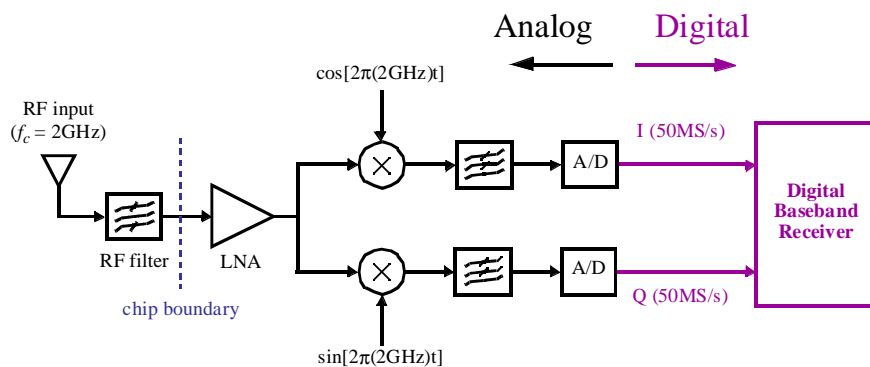

PicoRadio



## The Energy-Flexibility Gap

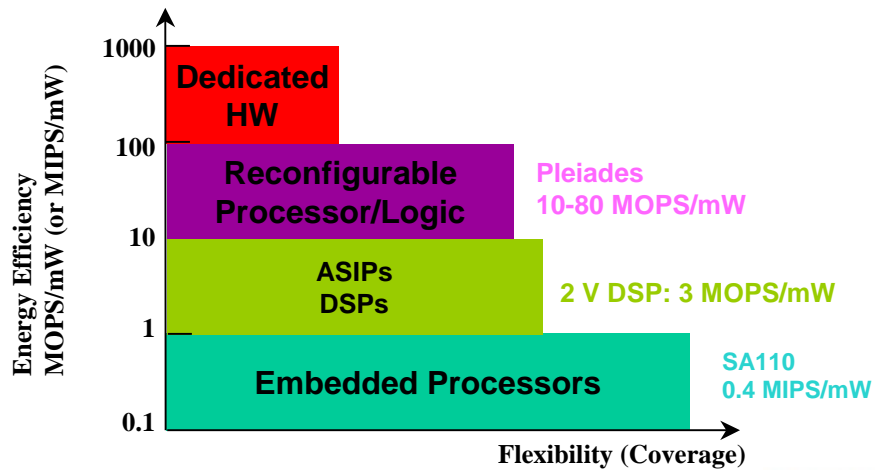

PicoRadio



## (Re)configurable Computing: Merging Efficiency and Versatility

*Spatially programmed connection of processing elements.*

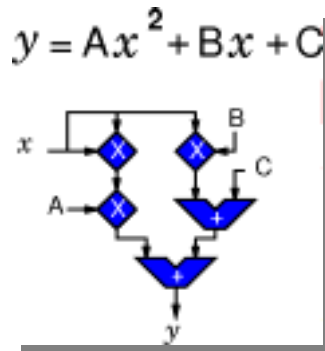

“Hardware” customized to specifics of problem.

Direct map of problem specific dataflow, control.

Circuits “adapted” as problem requirements change.

PicoRadio



## Architecture Comparison

**LMS Correlator at 1.67 MSymbols Data Rate**  
**Complexity: 300 Mmult/sec and 357 Macc/sec**

Type	Power	Area
TMS320C54*	460 mW	1089 mm <sup>2</sup>
Pleiades	18.09 mW	5.448 mm <sup>2</sup>
ASIC [Zhang]	3 mW	1.5 mm <sup>2</sup>

**16 Mmacs/mW!**

Note: TMS implementation requires 36 parallel processors to meet data rate - validity questionable

PicoRadio



## Intercom TDMA MAC Implementation alternatives

	ASIC	FPGA	ARM8
Power	0.26mW	2.1mW	<b>114mW</b>
Energy	10.2pJ/op	81.4pJ/op	$n \cdot 457pJ/op$

- ASIC: 1V, 0.25  $\mu$ m CMOS process
- FPGA: 1.5 V 0.25  $\mu$ m CMOS low-energy FPGA
- ARM8: 1 V 25 MHz processor;  $n = 13,000$
- Ratio: 1 - 8 -  $\gg$  400

**Idea: Exploit model of computation: concurrent finite state machines, communicating through message passing**

PicoRadio



## The Integrated PicoNode

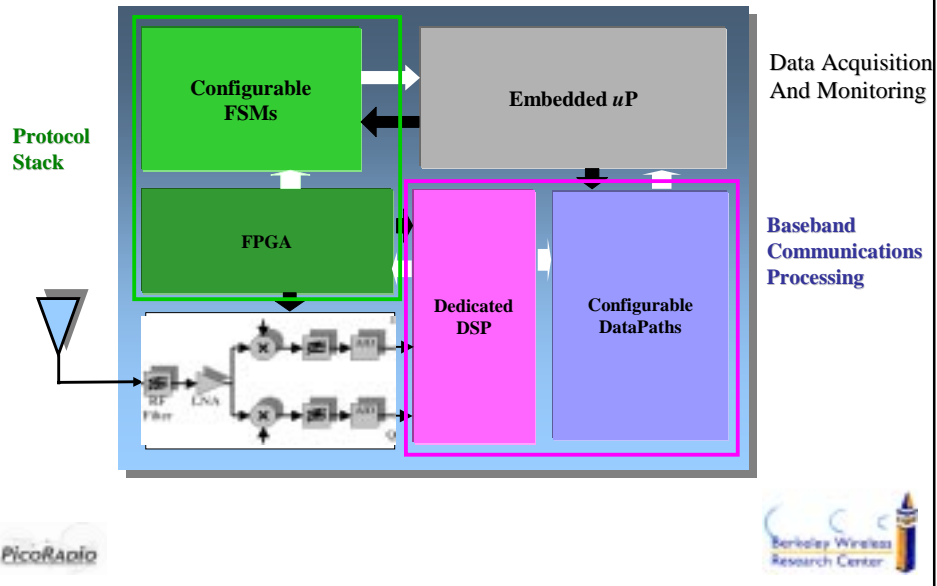

## A Testbed for PicoRadio

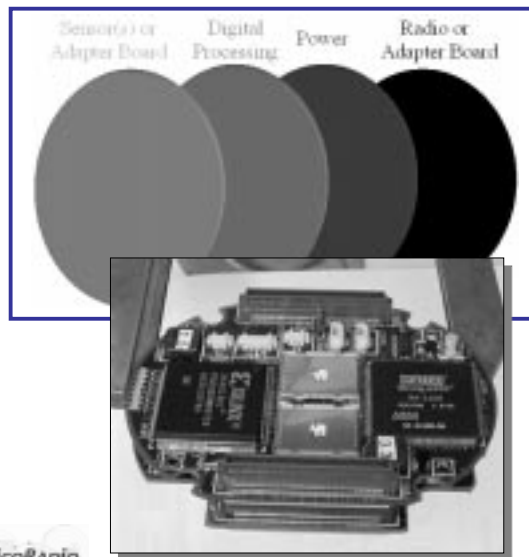

- Flexible platform for experimentation on networking and protocol strategies
- Size: 3" x 4" x 2"
- Power dissipation < 1 W (peak)
- Multiple radio modules: Bluetooth, Proxim, ...
- Collection of sensor and monitor cards
- Fully operational by late spring (including software support system)!

## TCI — An Exercise in Integrated Wireless Node Design

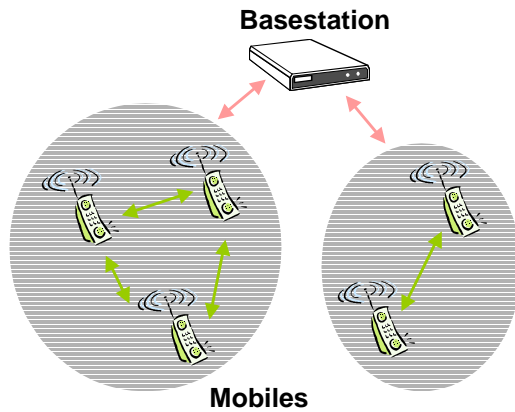

- Known and tested specification of limited complexity allows focus on architectural implementation methodology
- Two-chip implementation leverages separates between analog (RF) and digital design concerns
- Duration of exercise: 1 year (summer '00)

Up to 20 users per cell @ 64 kbit/sec per link  
 TDMA selected as MAC protocol

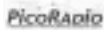

## Two-Chip Intercom (TCI)

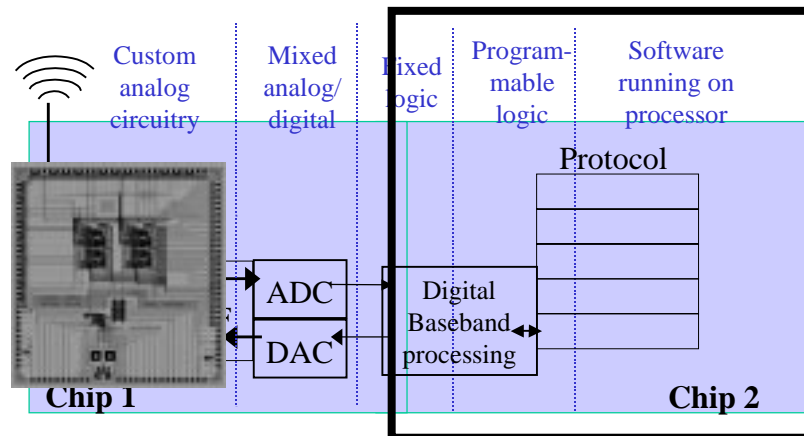

Direct down-conversion front-end  
 (Yee et al)



## TCI Implementation Platform

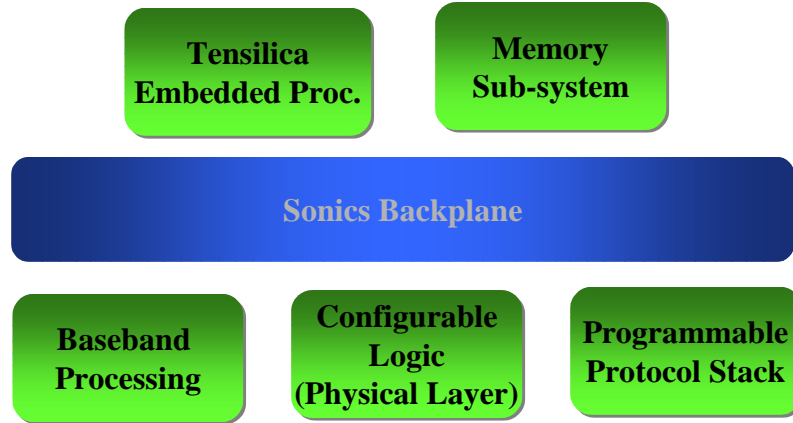

Benefit: Build library of computational and networking modules (and models)

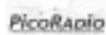

## The Holy Grail: Energy Scavenging

Energy Sources	Power (Energy) Density
Batteries (Zinc-Air)	1050 - 1560 mWh/cm <sup>3</sup>
Batteries (rechargeable Lithium)	300 mWh/cm <sup>3</sup> (3 - 4 V)
Solar	15 mW/cm <sup>2</sup> - direct sun 1mW/cm <sup>2</sup> - ave. over 24 hrs.
Vibrations	0.05 - 0.5 mW/cm <sup>3</sup>
Inertial Human Power	3E-6 mW/cm <sup>2</sup> at 75 Db
Acoustic Noise	9.6E-4 mW/cm <sup>2</sup> at 100 Db
Non-Inertial Human Power	1.8 mW (Shoe inserts)
Nuclear Reaction	80 mW/cm <sup>3</sup>
One Time Chemical Reaction	1E6m Wh/cm <sup>3</sup>
Fluid Flow	
Fuel Cells	300 - 500 mW/cm <sup>3</sup> ~4000 mWh/cm <sup>3</sup>

SOURCE:  
P. Wright & S. Randy  
UC ME Dept.



