

# UWB Antenna

- UWB antenna for indoor wireless applications
  - Broadband
  - Omni-directional
  - Small size
- Small size → Narrowband
  - Antenna Q  $\sim (\lambda^3)/(\text{antenna size})$
  - Almost impossible to have 50ohm radiation resistance over the whole bandwidth
- Small size → Omni-directional
  - Phase difference on the antenna is small

6cm Dipole Antenna  
Input Impedance

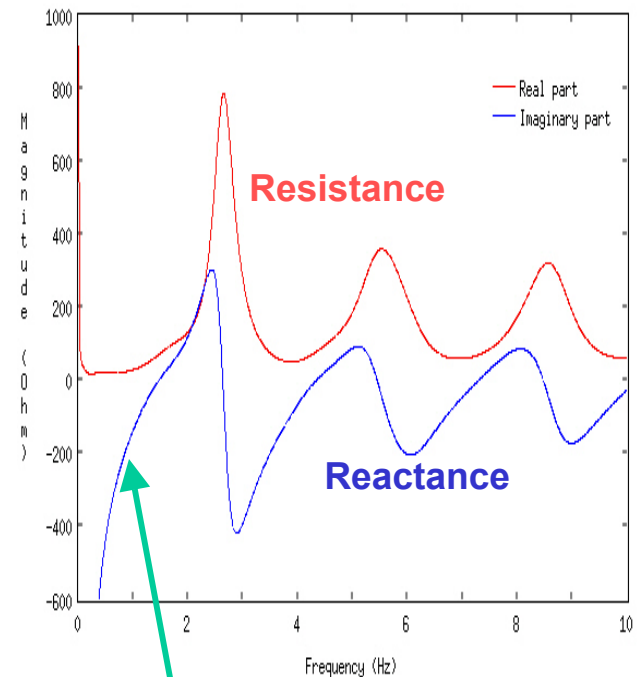

Reactance Dominates!

# Small Antenna Modeling

Take small Loop Antenna as an example

- E-fields in all directions are with almost the same waveform
- Only one resistor in our model
- By superposition, waveform across  $R_{rad}$  is equal to the far-zone E-fields
- Can estimate radiated E-field in SPICE

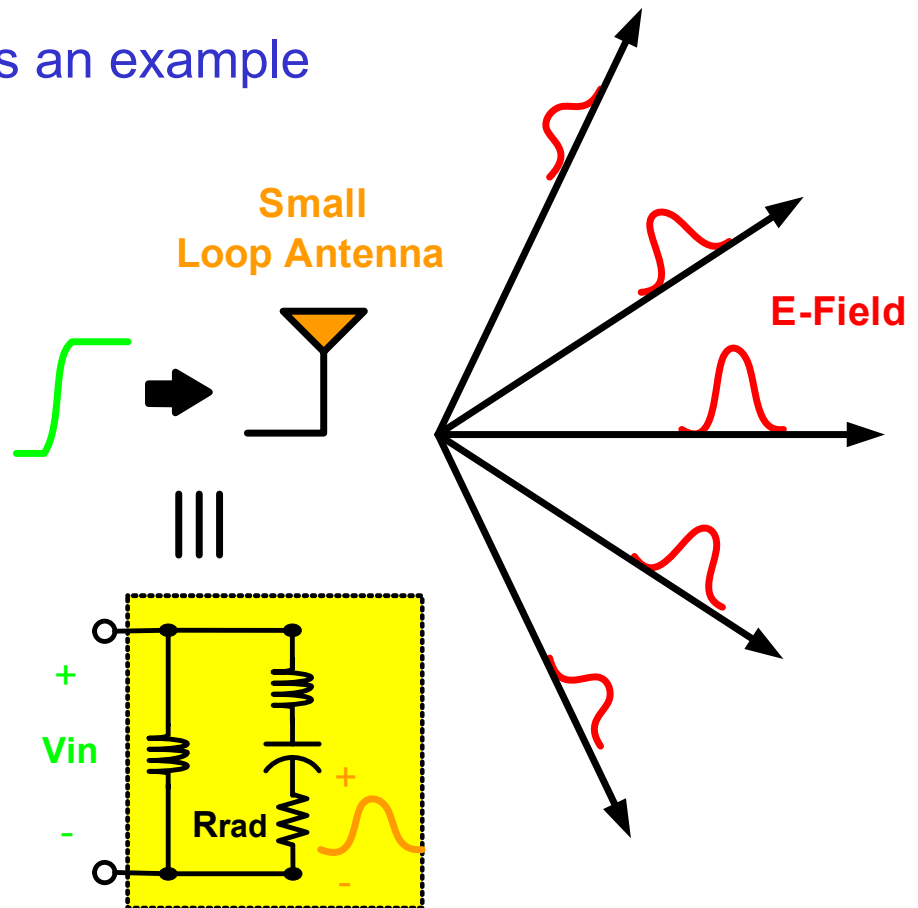

# UWB Pulser/Antenna Co-design

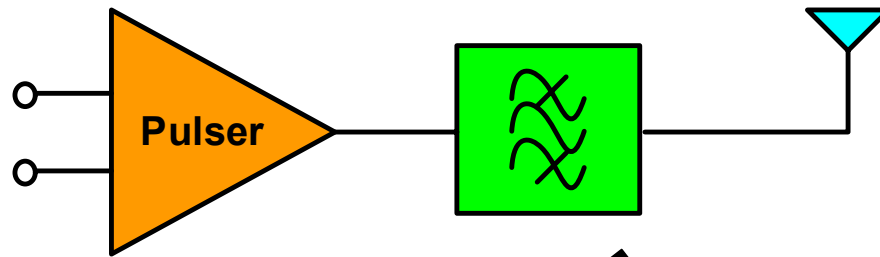

- Large Current Radiator (LCR) as the UWB antenna
- Notch filter for FCC radiation mask

- H-bridge pulser to drive inductive load
- Flexible driving force by parallel structure

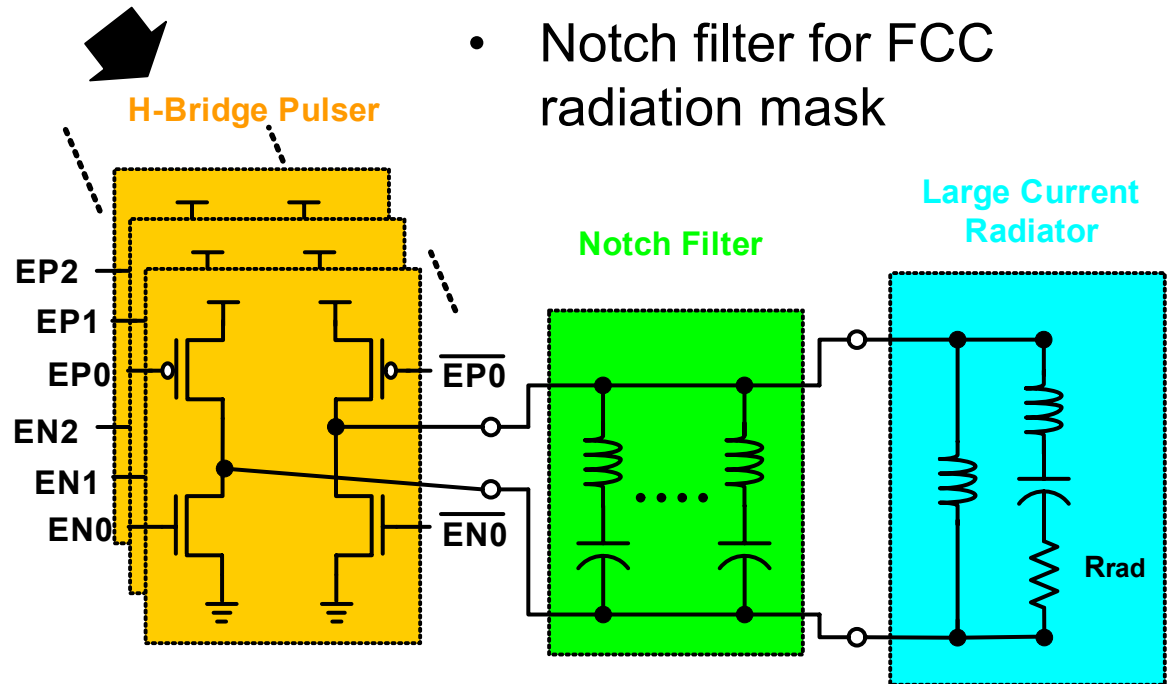

# H-bridge Simulation Results

- Doublet is generated
- Pulse-width  $\sim 1\text{ns}$
- Smoothed after low-pass filtering at the receiver

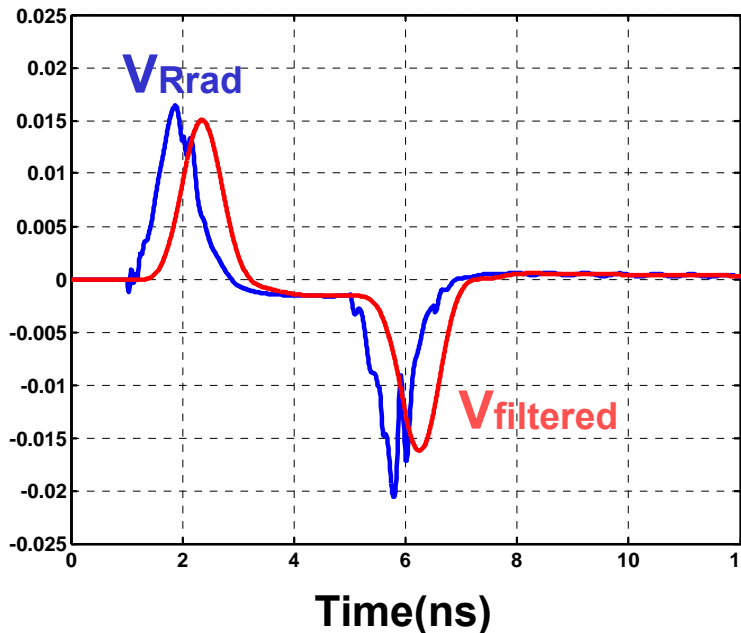

- Meet FCC's rule
- EIRP will increase when PRF(Pulse Repetition Freq) increases

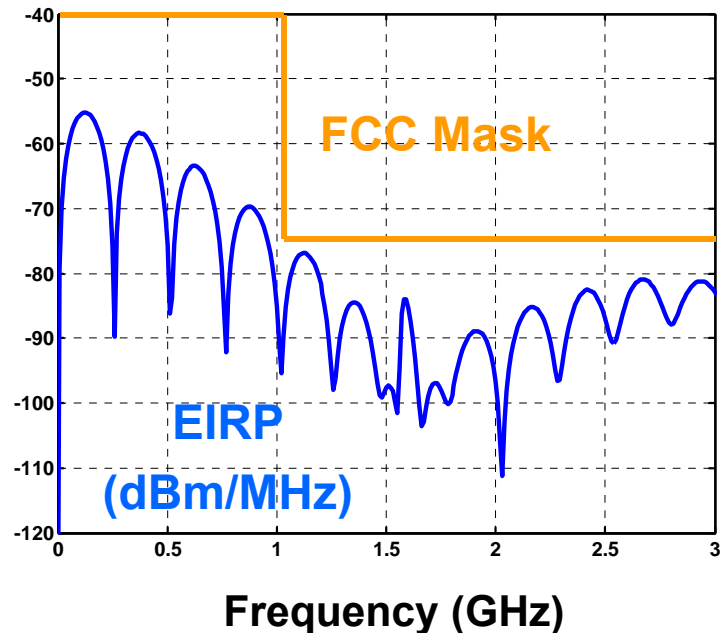

# Sub-mW UWB LNA Design

- Specifications
  - Fully-differential for on-chip interference immunity
  - Voltage Gain  $> 15\text{dB}$
  - 3dB BW : 0.1~1GHz
  - NF  $< 6\text{dB}$
  - Linearity : doesn't matter
  - Input impedance : 50ohm
  - **Goal : Minimize power consumption ( $< 1\text{mW}$ )**
- Low input impedance sets the power consumption
- What's the best LNA topology?

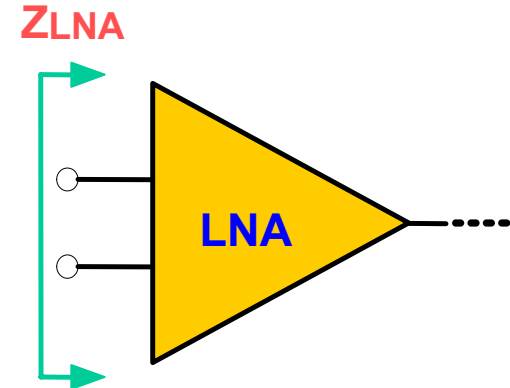

# Current-Reuse Technique

## Shunt-Feedback

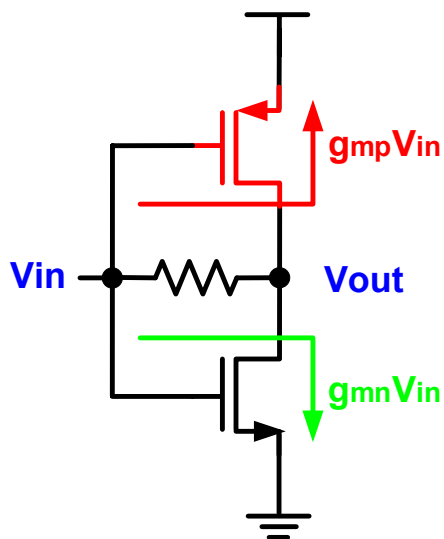

$$R_{in} = 1/(g_{mn} + g_{mp})$$

$$R_{in,diff} = 2/(g_{mn} + g_{mp})$$

- PMOS are added in as amplifying devices
- No extra DC current
- $G_m = g_{mn} + g_{mp}$
- $R_{in}$  is halved
- Voltage gain is doubled
- NF decreased by 3dB
- BW decreased but OK

## Common-Gate

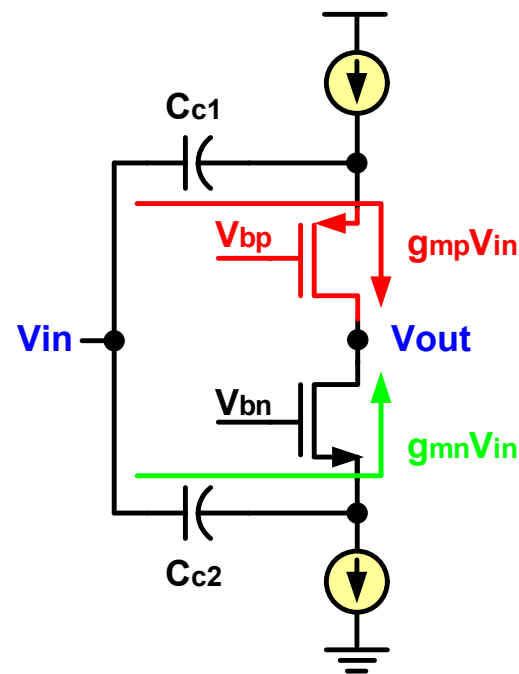

$$R_{in} = 1/(g_{mn} + g_{mp})$$

$$R_{in,diff} = 2/(g_{mn} + g_{mp})$$

# FB/CG Hybrid LNA

- $M_{p1}/M_{n1}/R_{f1}$  act as FB Amp to  $V_{in+}$  and CG Amp to  $V_{in-}$
- $M_{p2}/M_{n2}/R_{f2}$  act as FB Amp to  $V_{in-}$  and CG Amp to  $V_{in+}$
- $R_{in} = 1 / [ 2 * (g_{mn} + g_{mp}) ]$   
For  $R_{in} = 50\text{ohm}$ ,  
 $g_{mn} = g_{mp} = 5\text{mA/V}$   
→ 8 times smaller than 40mA/V in CG or Shunt-FB amplifier!  
→ sub-mW LNA feasible
- $A_v = 2 * (g_{mn} + g_{mp}) * R_f$

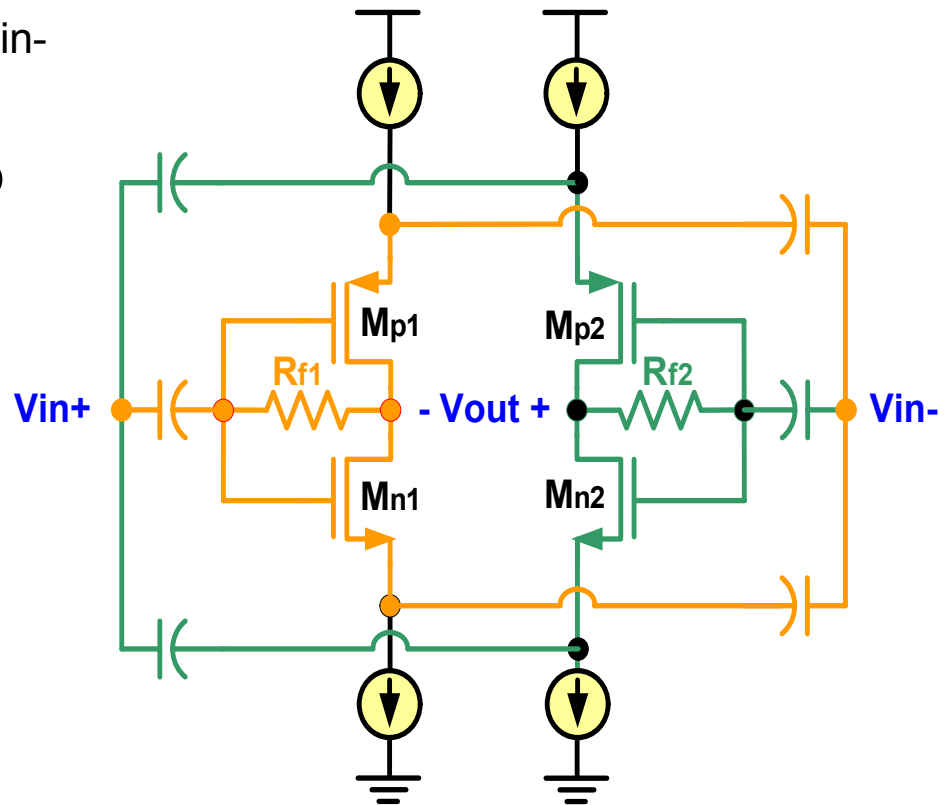



# UWB LNA Layout w/o Capacitors

- ST Microelectronics 0.13um CMOS triple-well process
- Layout area: 59um x 45um
- Common-centroid layout for good transistor matching
- Dummy for good resistor matching
- Capacitors not shown

